



***GREEN STORMWATER INFRASTRUCTURE***  
***LOW IMPACT DEVELOPMENT STANDARDS***

## Acknowledgements

---

### BERNALILLO COUNTY

- Dan McGregor, PG, CPG
- Kali Bronson, NGICP
- Megan Marsee
- Paulina Aguilera-Eaton, PLA
- Kevin Grovet, PE
- Julie Luna
- Richard Meadows, AICP

### BOHANNAN HUSTON

- Sarah Ganley, PE, ENV SP
- Vince Steiner, PE
- Savannah Maynard
- Rob Salazar, EI
- Joey Bobinsky, EI

### MRWM

- Tess Houle, PLA, ASLA
- Aaron Zahm, PLA, ASLA, LEED AP

Thank you to the following for their time, expertise, and major contributions to this document:

- Aaron Sussman, AICP
- Blaine Carter, PE
- Brad Catanach, PE

In addition, thank you to George Radnovich and Andrew Bernard with Sites Southwest. This document is a continuation of work performed by Sites Southwest in December 2017, [Bernalillo County Green Stormwater Infrastructure: Low Impact Design Strategies for Desert Communities](#). Finally, thank you to Melissa McDonald and Zoe Isaacson with the City of Santa Fe and to Chris Green and Ken Romig with Consensus Planning for their independent review and thoughtful critique of this document.

**TABLE OF CONTENTS**

Acknowledgements ..... 1

Introduction ..... 3

1 | Locations for GSI/LID BMPs ..... 6

2 | Benefits of Implementing GSI/LID BMPs ..... 10

3 | Regulatory Requirements for Implementing GSI/LID BMPs..... 12

4 | Stormwater Quality Design Storm and Design Volume 14

5 | GSI/LID BMPs..... 16

**Curb Opening ..... 18**

**Stormwater Harvesting Basin ..... 20**

**Stormwater Bumpout ..... 22**

**Bioswale..... 24**

**Depressed Median..... 26**

**Infiltration Trench..... 28**

**Check Dam ..... 30**

**Outlet Control Structure..... 32**

**Permeable Pavement..... 34**

**Treatment Train Examples ..... 36**

6 | GSI/LID BMP Design and Construction ..... 38

7 | GSI/LID BMP Inspection and Maintenance..... 44

8 | Mulch in GSI/LID BMPs ..... 46

9 | GSI/LID Plant Selection..... 49

Glossary ..... 55

Appendix: Plant List ..... 59

**LIST OF TABLES**

Table 1: Stormwater Quality Design Storm Rainfall Depths by Development Type & Land Treatment.....15

Table 2: Summary of Benefits by GSI/LID BMP .....16

Table 3: Typical Design Data Required for GSI/LID BMPs..42

Table 4: Ecological Biomes in the Middle Rio Grande Watershed .....50

Table 5: Arid Environment Establishment Periods .....53

Table 6: Establishing Guidelines for GSI/LID Features.....54

**LIST OF FIGURES**

Figure 1: Example of Urban Type Road with Depressed Median ..... 6

Figure 2: Example of Rural Type Road with Bioswale ..... 7

Figure 3: Examples of Landscape/Buffer Zones with GSI/LID BMPs..... 8

Figure 4: Example of a Landscaped Parking Area with GSI/LID BMPs..... 9

Figure 5: Examples of Site Development Applications with GSI/LID BMPs..... 9

Figure 6: Examples of Traffic Calming Applications: Landscaped Area Between Sidewalk and Roadway .....11

Figure 7: Preferred Mulch Type: Shredded, Partially Composted Wood Mulch .....47

Figure 8: Mulch Selection for GSI/LID BMPs .....48

Figure 9: Ecological Biome Selection Flow Chart.....50

Figure 10: Elevation Zones across Bernalillo County .....51

Figure 11: Geographic Area for Elevation Zones .....51

Figure 12: Planting Locations within GSI/LID BMPs.....52

## Introduction

---

### *Overview*

Green Stormwater Infrastructure (GSI) and Low Impact Development (LID) are approaches to stormwater management. These approaches mimic natural processes to improve water quality and to mitigate environmental impacts, as well as to provide other benefits. The fundamental goal, and a direct benefit, in implementing GSI/LID Best Management Practices (BMPs) is to reduce the amount of stormwater runoff and pollution reaching surface waters and thereby, adversely impacting the watershed. GSI/LID practices are designed to address smaller rainfall events by creating a “break” in directly connected impervious areas (DCIA). DCIAs account for the majority of stormwater runoff in developed areas; by breaking up impervious areas, such as parking lots, with landscape areas that feature GSI/LID BMPs, stormwater runoff from smaller rain events can be reduced or eliminated.

The *Green Stormwater Infrastructure/Low Impact Development Standards* document identifies BMPs for GSI/LID appropriate for the arid environment of the Middle Rio Grande Valley.

The *Green Stormwater Infrastructure/Low Impact Development Standards* also support Bernalillo County’s Stormwater Quality Ordinance and Water Conservation Ordinance and represent an increased commitment on the part of the County toward the goal of broad implementation of GSI/LID. GSI/LID is a direct means of complying with the

County’s Federal Municipal Separate Storm Sewer System (MS4) National Pollutant Discharge Elimination System (NPDES) Permit. Though guidelines for the use of GSI/LID BMPs have been provided in the past, this document contains additional guidance and best practices for design and maintenance. It also provides detailed drawings approved by the County. Users should note this document constitutes an update to the December 2017 [Bernalillo County Green Stormwater Infrastructure: Low Impact Strategies for Desert Communities](#).

Additionally, this document provides guidance to make it easier for design professionals to reference and to implement BMPs. In addition to the locations and contexts in which GSI/LID BMPs are appropriate, this document outlines Bernalillo County regulatory requirements and provides detailed information to support sound GSI/LID BMP design and construction in Bernalillo County’s arid environment. The guidance should be applied to new development and to redevelopment projects, as well as to roadway corridors.

### Key Definitions

**Green Stormwater Infrastructure (GSI)** is a method of sustainable stormwater management that focuses on treating stormwater runoff prior to it entering rivers, streams, aquifers, and other waterways by leveraging the ecological functions of living, natural systems.

**Low Impact Development (LID)** refers to design and development practices that work with nature to reduce the stormwater runoff volume generated and to minimize or to eliminate adverse impacts to stormwater quality.

**Best Management Practices (BMPs)** refers to a set of methods that detain, disperse, attenuate, infiltrate, and/or filter stormwater runoff from impervious surfaces such as streets, sidewalks, rooftops, and parking areas. These practices are designed to manage stormwater runoff and to improve water quality by preventing or reducing pollutants in stormwater runoff.

### *Purpose of GSI/LID Standards*

The following describe the key reasons for implementing GSI/LID standards:

**To Advance Best Management Practices in Stormwater Management and Pollution Reduction:** GSI/LID practices, as reflected in this document and in the Bernalillo County Technical Standards, are an approach to stormwater management that leverages both engineering and ecosystem services. The intent of GSI/LID practices is to mimic predevelopment hydrology by managing stormwater as close to where it would naturally fall as possible.

**To Improve Quality of Life:** Implementation of GSI/LID practices makes Bernalillo County an increasingly desirable place to live. It contributes to better quality of life by improving community aesthetics, mitigating impacts from changing climate, conserving potable water, improving air quality, increasing tree canopy, and improving stormwater quality.

**To Meet Federal Requirements:** Bernalillo County also encourages use of GSI/LID practices as a means of meeting the MS4 Permit requirements.

**To Meet Bernalillo County Requirements:** Bernalillo County requires GSI/LID BMPs be considered as part of all site development plans. These plans are subject to review by Bernalillo County staff (who are also available to provide guidance during the site plan development process). Per the MS4 Permit requirements, developers **must** manage the stormwater quality design volume on-site. GSI/LID BMPs can be used to meet those requirements. Developers also are required to submit a **Stormwater Post-Construction Green Stormwater Infrastructure/Low Impact Development Best Management Practices Evaluation Form** as part of the Grading & Drainage Plan. This form documents the opportunities to implement GSI/LID BMPs for a project, further emphasizing that GSI/LID BMPs manage stormwater quality design volume as required by the Bernalillo County Stormwater Quality Ordinance.

The process and procedures developers and project designers must follow in the implementation of GSI/LID BMPs are described in **Section 3: Regulatory Requirements for Implementing GSI/LID**.

**To Integrate with Bernalillo County Technical Standards:** This document was developed in conjunction with the update to the Bernalillo County Technical Standards, completed in 2022. The Technical Standards provide design requirements and considerations for transportation and site infrastructure in unincorporated areas of Bernalillo County. Whereas the Technical Standards provide guidance on appropriate locations for GSI/LID BMPs, this document provides direction on the specific application of GSI/LID BMPs within those appropriate locations.

**To Enhance Public Understanding and To Increase Application of GSI/LID:** An important objective of this document is to improve the public's understanding and expectations about what GSI/LID is and what it looks like, as ecologically responsible designs may differ from people's expectations. Bernalillo County strives to be a leader in sustainable design and infrastructure, and the County intends for the techniques and the guidance provided in this document to be utilized by other agencies and developers in the Middle Rio Grande Valley.

### *Intended Users of This Document*

This document is a guide for both private development and publicly-funded projects in the installation of GSI/LID BMPs. For **private developers**, the GSI/LID Standards serve to explain the County review process and to provide guidance on appropriate BMPs. For **Bernalillo County staff** and consultants, this document is specifically intended as a resource for inclusion of GSI/LID BMPs in publicly-funded projects.

### Contents of the GSI/LID Standards Document

**Regulatory Requirements:** Bernalillo County regulatory environment and review process.

**BMP Technical Guidance Sheets:** Definitions, general design, and maintenance guidance, as well as appropriate locations for GSI/LID BMPs.

**BMP Standard Drawings:** Detailed guidance on the design and construction of BMPs.

**Treatment Train Guidance:** Examples of how BMPs can be used in combination (i.e., treatment trains).

**General Considerations:** Appropriate GSI/LID BMP selection, maintenance considerations, and other best practices for design and construction.

**Mulch:** Guidance on types, preferred use, and best practices for mulch in GSI/LID BMPs.

**Plant Selection:** Identification of native and drought-tolerant plants appropriate for GSI/LID BMP locations across Bernalillo County.

## 1 | Locations for GSI/LID BMPs

### *General Application for GSI/LID BMPs*

GSI/LID BMPs included in this document can be used in various applications, including in public infrastructure projects, in roadway rights-of-way and medians, in parking lots, and as part of public and private site developments. The application of GSI/LID BMPs may vary depending on site conditions and on project needs.

**Commercial applications** include GSI/LID BMPs that manage stormwater runoff from impervious surfaces, such as parking lots, roadways, sidewalks, and rooftops, as well as incorporation into on-site landscaping and stormwater management facilities (e.g., stormwater harvesting ponds, bioswales, etc.). Projects in the **public right-of-way** also produce runoff from impervious surfaces and should incorporate GSI/LID BMPs into roadway medians, landscape/buffer zones, open spaces, and alongside trail facilities.

GSI/LID practices are also appropriate in **residential settings**, and Bernalillo County offers incentive programs for the use of rain barrels and cisterns. See the Bernalillo County Water Conservation Incentive Program webpage ([www.bernco.gov/waterconservation](http://www.bernco.gov/waterconservation)) for additional information. For more information on rainwater harvesting on a residential scale go to [www.bernco.gov/rainwater](http://www.bernco.gov/rainwater).

The typical applications listed in the following sections are not intended to be an exhaustive set of practices, and other techniques may be approved by Bernalillo County upon review. As examples, stormwater planters, tree boxes, and infiltration chambers are typically manufactured proprietary GSI/LID BMP solutions; as such, these are not detailed in the

Bernalillo County GSI/LID Standard Drawings and technical guidance sheets. These are, however, techniques Bernalillo County encourages project designers to consider.

### *Considerations by Road Type*

**Urban type roads** typically manage stormwater through curb and gutter. They may include medians and landscape buffers. As such, a variety of opportunities exist for the application of GSI/LID BMPs in urban type roads.

**Figure 1: Example of Urban Type Road with Depressed Median**



Source: K. Bronson | Location: Tucson, AZ

**Rural type roads** do not typically feature curb and gutter. Opportunities to utilize GSI/LID BMPs in rural type roads include bioswales and stormwater harvesting basins. See the Bernalillo County Technical Standards for additional information on road types.

*Figure 2: Example of Rural Type Road with Bioswale*



Source: K. Bronson | Location: Bernalillo County

### *Typical Locations for GSI/LID BMPs*

#### **Roadway Median**

Medians may be landscaped to increase roadway aesthetics, to improve safety, and to provide traffic calming benefits. Medians are conducive to GSI/LID practices, as they can easily be modified into low points where stormwater can be collected and treated. By modifying the curb and by lowering the grade, stormwater can enter the basin from the roadway. Given their linear characteristics, medians are also conducive to providing conveyance to other stormwater management installations.

Typical GSI/LID BMPs for roadway medians include:

- Bioswale
- Stormwater Harvesting Basin
- Check Dam
- Depressed Median
- Curb Openings with Sediment Traps
- Infiltration Trench



**Landscape/Buffer Zone**

Landscape/buffer zones are generally located between the sidewalk and the curb along a roadway. Examples include bumpouts and curb extensions at intersections or at mid-block locations. They provide safety and traffic calming benefits, improve aesthetics, and enhance the pedestrian experience. These zones are conducive to GSI/LID BMPs, because they can easily be modified as low points where stormwater can be collected. By using curb openings and by lowering the grade, stormwater can enter the landscape/buffer zones from the roadway or other impervious areas. Given their linear characteristics, landscape/buffer zones are also conducive to providing conveyance to other stormwater management installations.

Typical GSI/LID BMPs for landscape/buffer zones include:

- Bioswale
- Infiltration Trench
- Stormwater Bumpout
- Curb Openings with Sediment Traps
- Stormwater Tree Box\*
- Stormwater Planter\*

*\*Not included in GSI/LID Standards document since the designs are proprietary.*

**Figure 3: Examples of Landscape/Buffer Zones with GSI/LID BMPs**



Source: K. Bronson | Location: Bernalillo County (left) Albuquerque, NM (right)



Source: J. Luna | Location: Albuquerque, NM

**Landscaped Parking Areas**

Parking areas offer opportunities for stormwater management, as they typically include landscape strips and basins utilized for on-site stormwater management. Similar to roadway medians and buffers, landscaped areas in parking lots can easily be modified as low points where stormwater can be collected. By using curb openings and by lowering the grade, stormwater can enter the BMPs from drive aisles and from parking stalls. Additionally, angled parking can be used to reduce impervious areas, because it can accommodate more parking spaces within a smaller area.

Typical GSI/LID BMPs for landscaped parking areas include:

- Stormwater Harvesting Basin
- Stormwater Bumpout
- Bioswale
- Infiltration Trench

**Figure 4: Example of a Landscaped Parking Area with GSI/LID BMPs**



Source: S. Osterman | Location: Bernalillo County

**Site Development Applications**

GSI/LID BMPs can be applied on most development and redevelopment sites, both public and private, to enhance community aesthetics and to manage stormwater as close as possible to where it falls naturally.

Typical GSI/LID BMPs for site development applications include:

- Stormwater Harvesting Basin
- Bioswale
- Infiltration Trench
- Check Dam
- Permeable Pavement

**Figure 5: Examples of Site Development Applications with GSI/LID BMPs**



Source: BHI/MRWM (left), S. Osterman (right)  
Location: Albuquerque, NM (left), Bernalillo County (right)

## 2 | Benefits of Implementing GSI/LID BMPs

The fundamental goal in implementing GSI/LID BMPs is to reduce the amount of stormwater runoff and pollution reaching surface waters and thereby, adversely impacting the watershed. In this way, GSI/LID is a direct means of complying with the County's MS4 Permit.

GSI/LID practices are designed to address smaller rainfall events by creating a "break" in directly connected impervious areas (DCIA). DCIAs account for the majority of stormwater runoff in developed areas; by breaking up impervious areas, such as parking lots, with landscape areas that feature GSI/LID BMPs, stormwater runoff from smaller rain events can be reduced or eliminated.

### Adverse Effects of Stormwater Runoff

During rainstorms, stormwater runs from impervious surfaces, such as streets and parking lots, picking up contaminants, such as sediment, trash, debris, oil, grease, PCBs, pesticides, bacteria (E. coli), and other chemicals.

Concentrated stormwater runoff from impervious surfaces can also cause erosion, increasing the sediment load in stormwater runoff. Sediment in stormwater runoff holds on to contaminants like oil and grease, PCBs, and pesticides, and may increase the temperature of the water in the river, negatively impacting the animals and insects living there.

### Direct Benefits

Direct benefits of GSI/LID include stormwater management and pollution reduction. GSI/LID BMPs slow the flow of water during and after rainfall events (i.e., peak flow attenuation), therefore reducing erosion and promoting sediment capture to ensure that landscaping and stormwater management areas remain durable and functional over the long-term. GSI/LID BMPs also improve surface water quality by filtering and removing pollutants and by capturing floatables, trash, and other debris.

By adding landscaped areas that mimic natural conditions, GSI/LID increases infiltration and groundwater recharge. Collectively, BMPs promote healthier waterways and improve overall stormwater quality, thereby meeting MS4 Permit requirements.

### Co-Benefits

In addition to stormwater management and pollution reduction, GSI/LID provides a range of co-benefits that positively affect sustainability and overall quality of life in communities. These co-benefits include:

#### Encouraging Water Conservation

A sustainable landscape design in an arid region like Bernalillo County needs to include GSI/LID. By harvesting rainwater and using native/drought-tolerant plants, GSI/LID BMPs conserve potable water. Incorporating GSI/LID in landscaping can provide significant long-term water savings.

#### Reducing Urban Heat Island and Climate Change Impacts

The presence of landscaped areas can reduce the impacts of climate change and the urban heat island effect by minimizing paved surfaces that absorb and re-emit heat from

the sun. Landscaped areas that include trees provide shade and cooling in urban areas.

### Increasing Tree Canopy and Improved Air Quality

Trees used in GSI/LID features contribute to improved air quality and mitigate urban heat island effect. They also increase shade, create wildlife habitat, and improve general livability for residents.

### Creating Wildlife Habitat

GSI/LID installations replicate native ecosystems outside of the urban area; as such, they can create small pockets of wildlife habitat inside of urban areas. The use of native plant species in landscaping support local fauna and improve biodiversity.

### Providing Traffic Calming

GSI/LID techniques can be integrated into medians and buffer areas to provide traffic calming and safety benefits. Landscape areas between the sidewalk and roadway travel lanes can provide a buffer between motorists and pedestrians, while street trees and vegetation can reduce travel speeds and accidents.

### Improving Physical and Mental Health Outcomes

At a neighborhood scale, GSI/LID can provide opportunities for physical activity, which can lead to improved mental health by reducing stress and by promoting cognition.

### Addressing Environmental Justice

Environmental Justice means all people, regardless of race, color, national origin, or income, are entitled to equal protection from environmental risks. Communities with environmental justice issues often face a disproportionate share of adverse environmental impacts from industrial and governmental operations and policies. This can result in impacts from urban heat islands, industrial pollution, and air

pollution and impacts to health. GSI/LID can provide social, environmental, and economic benefits to communities and can address social inequity within these communities by providing access to parks and to green spaces and by creating a healthier environment where people live and work.

**Figure 6: Examples of Traffic Calming Applications: Landscaped Area Between Sidewalk and Roadway**



Source: NACTO, *Urban Street Stormwater Guide*

### Increasing Aesthetics

Well-designed GSI/LID BMPs can create visually interesting pockets of green space to enhance community aesthetics. GSI/LID can also provide social benefits when BMPs are integrated into outdoor recreation areas and other gathering places.

### 3 | Regulatory Requirements for Implementing GSI/LID BMPs

#### *Regulatory Context*

The US Environmental Protection Agency (EPA) issued the Middle Rio Grande NPDES MS4 Permit in 2014. In addition to general requirements to mitigate the presence of pollutants in stormwater runoff, the MS4 Permit **requires all new development and redevelopment projects that disturb greater than or equal to one acre, including projects less than one acre that are part of a larger common plan of development or sale, to manage the stormwater quality design volume on-site.** The MS4 Permit also requires evaluating opportunities for use of GSI/LID sustainable practices in site design and encouraging projects to incorporate such practices. These requirements apply to both public projects and to private developments.

In 2016, Bernalillo County followed and passed the Stormwater Quality Ordinance, Chapter 38, Article IV, to establish stormwater management requirements for the unincorporated area of Bernalillo County. In accordance with the MS4 Permit requirement, the ordinance requires all new development and redevelopment projects above the requirement threshold (disturbing one acre or more, or part of a common development) to implement post-construction water quality BMPs to manage the stormwater quality design volume on-site (refer to **Section 4**). The Stormwater Quality Ordinance also requires that GSI/LID practices be evaluated by applicants and that determination and inclusion of viable GSI/LID BMPs be implemented within projects.

In addition, the Bernalillo County Water Conservation Ordinance, Chapter 30, Article VII, requires all new development to implement indoor and outdoor water

conservation measures. These requirements vary based on the type of development. New commercial development on properties greater than or equal to one acre in size must implement four outdoor water conservation measures. One of the options specified in the Ordinance is to implement passive water harvesting on 45 percent of the landscape area. Passive water harvesting is a type of stormwater quality and GSI/LID BMP; examples of passive water harvesting features include stormwater harvesting basins, bioswales, stormwater bumpouts, and depressed medians. Therefore, incorporating GSI/LID BMPs into commercial development serves to meet Bernalillo County's requirements in both its Stormwater Quality and Water Conservation Ordinances. As maintenance of GSI/LID BMPs is essential to ensure long term functionality, projects that implement passive water harvesting features are also required to submit a Landscape Water Management Plan that communicates routine maintenance requirements.

Finally, all projects that retain or detain stormwater are subject to the Office of the State Engineer rule (NMAC 19.25.12.11.B) that all waters must infiltrate or must be released from detention within 96 hours. Additional information can be found in the [Green Infrastructure Implementation in New Mexico](#) document developed by the New Mexico Environment Department in coordination with the Office of the State Engineer.

#### *Bernalillo County Review Process*

Bernalillo County requires submittal of the *Stormwater Post-Construction Green Stormwater Infrastructure/Low Impact Development Best Management Practices Evaluation Form* for new development and redevelopment projects above the requirement threshold (disturbing one acre or more, or part of a common development). The County's *Stormwater Post-Construction Green Stormwater Infrastructure/Low Impact*

*Development Best Management Practices Evaluation Form* is used to document and track the County's compliance with MS4 Permit and ordinance requirements and to ensure that maintenance requirements for GSI/LID BMPs are transmitted to the facility owner. The form is available on the [Bernalillo County website](http://www.bernco.gov/gsi-lid) ([www.bernco.gov/gsi-lid](http://www.bernco.gov/gsi-lid)).

### When is GSI/LID Required?

All new development and redevelopment projects that disturb one acre or more, including projects less than one acre that are a part of a larger common plan of development or sale, must evaluate for opportunities to implement GSI/LID to manage the stormwater quality design volume on site. GSI/LID BMPs are encouraged for all new development and redevelopment projects, regardless of size.

In addition to the guidance contained in this document, Bernalillo County staff is available to consult with developers and project designers on the appropriate application of GSI/LID BMPs. Bernalillo County encourages developers to consider GSI/LID BMPs early in the site development process and that GSI/LID and stormwater quality BMPs be incorporated into the **grading and drainage plan**.

Applicants should maintain communication with Bernalillo County staff throughout the design process to ensure that goals are met in the final design. Early consideration of GSI/LID can also provide savings and benefits for developers and project designers, as it can be more complicated and expensive to integrate GSI/LID BMPs after the grading and drainage plan and the landscaping plans have been submitted for County review. Additional information on the County review process can be found in **Section 6: GSI/LID BMP Design and Construction**.

## 4 | Stormwater Quality Design Storm and Design Volume

The EPA MS4 Permit and the Bernalillo County Stormwater Quality Ordinance (Chapter 38, Article IV), require that the stormwater quality design volume (SWQV) be managed on site. The SWQV is derived from the stormwater quality design storm event and calculated using the rainfall depth from the 90th percentile storm event for new development projects and the 80th percentile storm event for redevelopment projects.

### Key Definitions

**New Development**, in relation to the retention of the stormwater quality design volume, is defined as a project that is developed on a site with little or no existing impervious cover. This can include an undeveloped property or a property that had previously been developed, but site improvements and impervious cover have been mostly or completely removed so that site constraint issues related to existing infrastructure no longer exist.

**Redevelopment**, in relation to retention of the stormwater quality design volume, is defined as a development project that alters the footprint of an existing site, building, or impervious area. Redevelopment projects have site constraints typically not found in new development projects.

### SWQV Calculation:

The entire site contributes to the SWQV, which is calculated using the appropriate land treatment types for the planned development (whether existing, new development, or redevelopment). The SWQV is derived from the stormwater quality design storm event and is calculated as follows. Stormwater quality design storm rainfall depths for development types and land treatments are summarized in Table 1.

- **SWQV Calculation for New Development** – The 90th percentile new development rainfall depth for Land Treatment D (0.615 inches) multiplied by the new development impervious (Land Treatment D) areas plus the new development rainfall depth for Land Treatment C (0.52 inches) multiplied by the new development Land Treatment C areas:

$$SWQV \text{ (cubic feet)} = [(0.615 \text{ inches}) \times (\text{Land Treatment D areas in sq. ft.}) + (0.52 \text{ inches}) \times (\text{Land Treatment C areas in sq. ft.})] / 12$$

- **SWQV Calculation for Redevelopment** – The 80th percentile rainfall depth for Land Treatment D (0.48 inches) multiplied by the redevelopment impervious (Land Treatment D) areas plus the redevelopment rainfall depth for Land Treatment C (0.41 inches) multiplied by the redevelopment Land Treatment C areas:

$$SWQV \text{ (cubic feet)} = [(0.48 \text{ inches}) \times (\text{Land Treatment D areas in sq. ft.}) + (0.41 \text{ inches}) \times (\text{Land Treatment C areas in sq. ft.})] / 12$$

All stormwater runoff from a site must receive stormwater quality treatment, and all BMPs must be sized for the SWQV for the tributary area. If a BMP is sized for the SWQV for the entire site, then the project designer must ensure that it collects runoff from the entire site and is not limited to a portion of the site. More often, site runoff is collected at multiple locations, requiring multiple properly sized BMPs.

See the Standard Drawings and Table 3 for stormwater quality design volume data required for project plans for GSI/LID BMPs.

**Table 1: Stormwater Quality Design Storm Rainfall Depths by Development Type & Land Treatment**

Development Type	Land Treatment	Rainfall Depth for SWQV Calculation
New Development	D	0.615"
New Development	C	0.52"
Redevelopment	D	0.48"
Redevelopment	C	0.41"

Source: [Estimating Predevelopment Hydrology in the Middle Rio Grande Watershed, New Mexico](#) (EPA Publication Number 832-R-14-007, Tetra Tech, 2014)

**Key Definitions**

**Land Treatment C:**

- Soil compacted by human activity with minimal vegetation including unpaved parking, roads, and walkways.
- Irrigated lawns and parks with slopes greater than 10 percent.
- Native grasses, weeds, and shrub areas and soil uncompacted by human activity with slopes at 20 percent or greater.
- Native grasses, weeds, and shrub areas with clay or clay loam soils and other soils of very low permeability, as classified by SCS Hydrologic Soil Group D.

**Land Treatment D:** Impervious areas such as pavement and roofs. This area includes ponds, channels, and wetlands, even if these areas are seasonally dry.

*Note: Land Treatments C and D follow the definition from the City of Albuquerque Development Process Manual (DPM) with minor modifications to Land Treatment C.*



## 5 | GSI/LID BMPs

### General Overview

This section highlights the most common and most appropriate GSI/LID BMPs for application in unincorporated Bernalillo County, given the arid environment and the desire to conserve water.

Table 2 presents the GSI/LID BMPs described in this document, along with typical benefits associated with these techniques. Each BMP is profiled on a following page in a **technical guidance sheet**. Each sheet contains a graphic depiction, design considerations, maintenance needs, appropriate locations and context, and complementary techniques, along with a **Standard Drawing** that indicates preferred design specifications and construction methods.









It is important to note the appropriate GSI/LID BMP may vary from the provided guidance depending on site specific conditions and the site location within the Middle Rio Grande region. Site features and conditions, as well as design considerations, should inform the selection of appropriate GSI/LID BMPs.

The BMPs presented in this section are not intended to be an exhaustive set of practices. Other techniques may be approved by Bernalillo County upon review. As examples, stormwater planters, tree boxes, and infiltration chambers are typically manufactured proprietary GSI/LID solutions; these are not detailed in the Bernalillo County GSI/LID Standard Drawings and technical guidance sheets but are techniques Bernalillo County encourages project designers to consider. Project designers may consult the December 2017 document [Bernalillo County Green Stormwater](#)

[Infrastructure: Low Impact Design Strategies for Desert Communities](#) for additional techniques and guidance.

GSI/LID BMPs designed in accordance with the Standard Drawings in this document, as well as properly located/applied, will be approved by Bernalillo County. Any design modifications to the Standard Drawings will be reviewed and evaluated on a project-by-project basis.

**Table 2: Summary of Benefits by GSI/LID BMP**

	Reduces or Regulates Runoff Rate or Volume	Filters Out Pollutants	Increases Infiltration	Captures Debris, Floatables & Sediment	Reduces Urban Heat Island Effect	Promotes Evaporation/Transpiration
 <b>Curb Opening</b>				✓		
 <b>Stormwater Harvesting Basin</b>	✓	✓	✓	✓	✓	✓
 <b>Stormwater Bumpout</b>	✓	✓	✓	✓	✓	✓
 <b>Bioswale</b>	✓	✓	✓	✓	✓	✓
 <b>Depressed Median</b>	✓	✓	✓	✓	✓	✓
 <b>Infiltration Trench</b>	✓	✓	✓	✓		
 <b>Check Dam</b>	✓		✓	✓		
 <b>Outlet Control Structure</b>	✓			✓		
 <b>Permeable Pavement</b>	✓	✓	✓		✓	

### *Application of BMPs and Treatment Trains*

GSI/LID BMPs can be used alone or in conjunction with other treatments. However, GSI/LID BMPs are most effective when used in various combinations – called treatment trains – tailored to a given site. A stormwater treatment train helps to maximize infiltration of stormwater and to capture pollutants in stormwater runoff before they reach the downstream receiving waters. This provides better overall results compared to the use of a single BMP. A treatment train can consist of multiple installations of one type of GSI/LID BMP (e.g., stormwater harvesting basins) or multiple BMPs (e.g., bioswales and check dams).

Examples of treatment trains that show how BMPs can function together to manage stormwater runoff can be found on pages 36-37. The treatment train on page 36 illustrates how permeable pavement, curb openings with sediment traps, a stormwater bumpout, and an infiltration trench collectively provide an effective GSI/LID installation adjacent to a roadway or to a parking lot. The treatment train on page 37 shows a combination of a bioswale, check dam, and stormwater harvesting basin as a GSI/LID solution that could fit into many development designs.

#### **Considerations for ADA Compliance**

All GSI/LID BMP installations should meet the Americans with Disabilities Act (ADA) Standards for Accessible Design requirements. Project designers should review and consider the intent of the ADA requirements when selecting BMPs for locations where pedestrians may be present.

# CURB OPENING



## CURB OPENING

An opening in a curb to allow stormwater from an impervious surface, such as roads, parking lots, or hardscape areas, to flow into an infiltration area. Typical design includes a sediment trap located behind the curb opening.

### DESIGN CONSIDERATIONS





- Can be used to retrofit existing projects, as well as can be constructed with new projects. Retrofit application will require sawcut and removal of existing curb and gutter.
- Recommend minimum curb opening length of 2-feet to prevent clogging.
- Recommend sediment trap to facilitate maintenance. There are many designs for sediment traps, and the County will consider alternatives to the Curb Opening Standard Drawing.
- Recommend minimum 2-inch elevation drop be provided from the curb opening flowline to the finished grade at back of curb to ensure positive drainage.
- Erosion protection must be provided downstream of the sediment trap.
- Size and place erosion protection as needed for design storm velocity and slope stabilization.
- Utilize the AASHTO Roadside Design Guide when placing and designing curb openings adjacent to travel ways.

### MAINTENANCE

- Inspect after storms > 0.25-inches; recommend a minimum of two inspections per year.
- Remove debris, trash, and accumulated sediment from curb opening and sediment trap. The accumulated sediment should be removed if it reduces the curb opening capacity.
- Check for and repair erosion issues.
- Routinely check curb opening for damage from vehicle strikes and repair, as necessary.
- Remove vegetation that obstructs flow into the infiltration area.

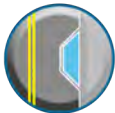

WHERE TO USE	
<input checked="" type="checkbox"/>	Urban Type Road
<input type="checkbox"/>	Rural Type Road
<input checked="" type="checkbox"/>	Streetside
<input checked="" type="checkbox"/>	Parking
<input checked="" type="checkbox"/>	Residential Development
<input checked="" type="checkbox"/>	Commercial/Institutional Development

FUNCTIONS WITH		
		
STORMWATER BASIN	STORMWATER BUMPOUT	BIOSWALE
		
DEPRESSED MEDIAN	INFILTRATION TRENCH	PERMEABLE PAVEMENT

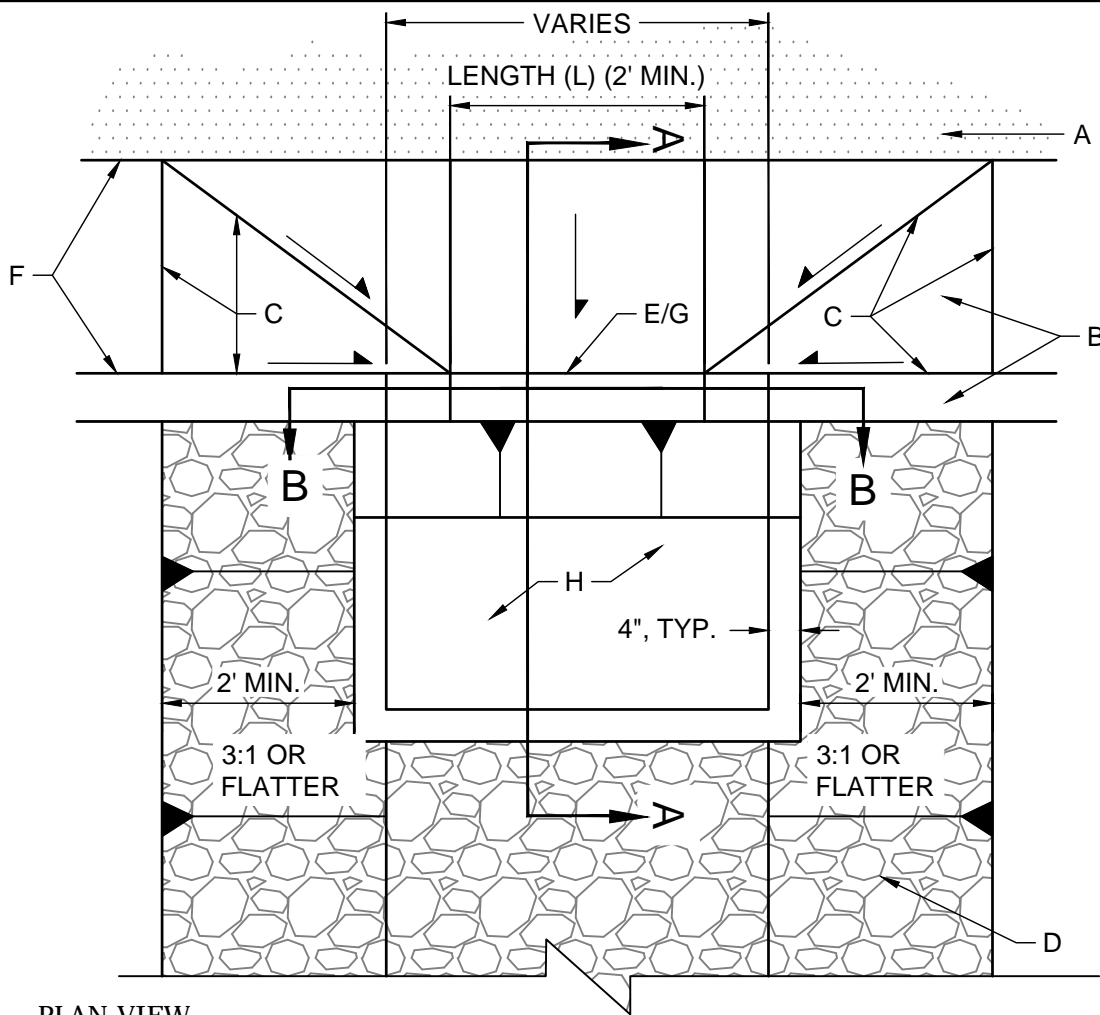

PLAN VIEW

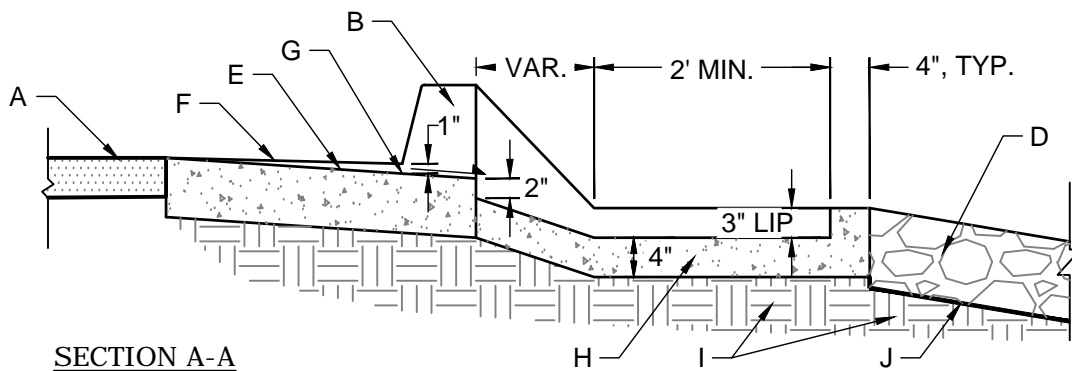

SECTION A-A

**GENERAL NOTES:**

1. SEE TECHNICAL GUIDANCE SHEET FOR DESIGN GUIDANCE AND CONSIDERATIONS.
2. CURB OPENING LENGTH (L) SHALL BE PROVIDED ON PROJECT PLANS (2' MIN.).
3. SEDIMENT TRAP SHOULD BE DESIGNED FOR CONTRIBUTING WATERSHED/SEDIMENT LOAD AND DESIGN HYDRAULIC CONDITIONS. DIMENSIONS SHOWN ARE FOR TYPICAL APPLICATION AND MAY BE MODIFIED BY PROJECT PLANS.
4. DETAIL AS SHOWN ASSUMES NEW CONSTRUCTION. MAY BE MODIFIED FOR RETROFIT CONSTRUCTION OF CURB OPENING.

**CONSTRUCTION NOTES:**

- A. ADJACENT ROADWAY/PARKING SURFACE.
- B. CURB OR CURB AND GUTTER PER PROJECT PLANS. STANDARD C&G PER COUNTY STANDARD DWG 2415A SHOWN.
- C. GUTTER TRANSITION PER COUNTY STANDARD DWG 2207 OR AS MODIFIED PER PROJECT PLANS.
- D. RIPRAP RUNDOWN OR EROSION PROTECTION. LAYOUT, DIMENSIONS, AND RIPRAP SIZE/THICKNESS PER PROJECT PLANS.
- E. DEPRESSED GUTTER AT CURB OPENING.
- F. NORMAL GUTTER.
- G. POINT OF MEASUREMENT FOR CURB OPENING FLOWLINE ELEVATION.
- H. CONCRETE SEDIMENT TRAP, 4" THICK. DIMENSIONS (LENGTH, WIDTH, AND DEPTH (IF DIFFERS FROM 3")) PER PROJECT PLANS.
- I. SUBGRADE BELOW SEDIMENT TRAP AND RIPRAP COMPACTED TO 95% MAX DENSITY.
- J. NON-WOVEN GEOTEXTILE FILTER CLOTH BETWEEN RIPRAP AND SUBGRADE.

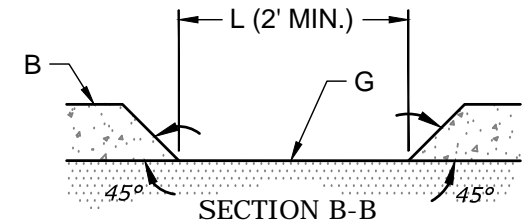

SECTION B-B



COUNTY OF BERNALILLO	
REVISIONS	CURB OPENING
GSI-01	JULY 2022

# STORMWATER HARVESTING BASIN



A stormwater harvesting basin is designed for capture and infiltration of stormwater runoff to support vegetation, to regulate discharge rates, and to improve water quality.

## STORMWATER BASIN

### DESIGN CONSIDERATIONS





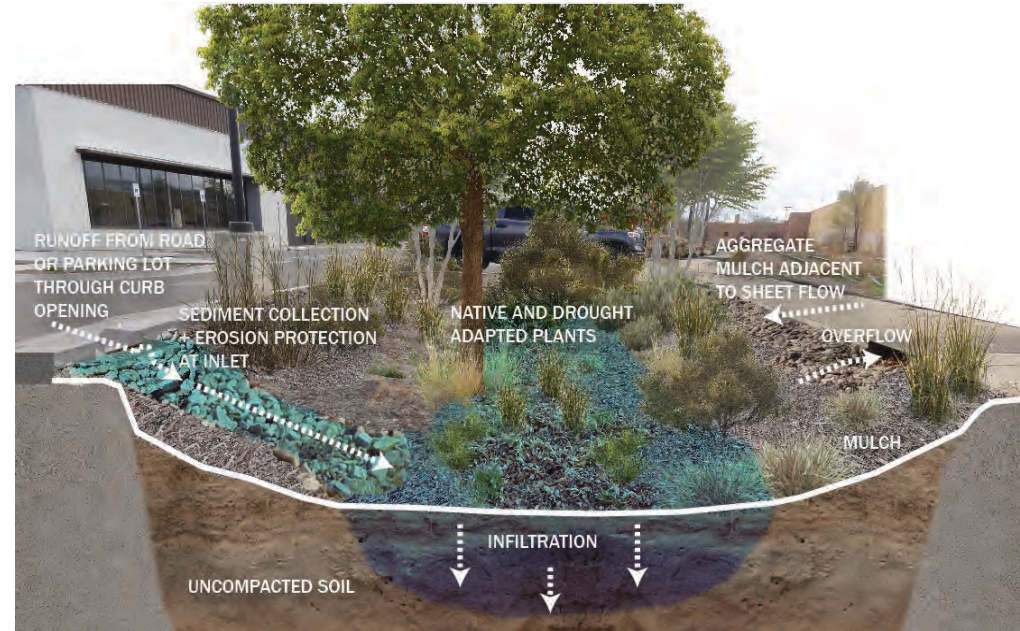

- Consider depth to the groundwater table and bedrock; refer to Section 6, General Design Principles.
- Recommend infiltration rate greater than 0.5-inch/hr. Infiltration testing should be conducted at the proposed basin bottom elevation. An underdrain may be required if the infiltration rate is less than 0.5-inch/hr.
- Ponded surface water shall infiltrate or be released from detention within 96 hours or less, if required by local ordinances.
- To maximize infiltration, do not compact bottom during or after construction and ensure that the bottom is scarified per the standard drawing.
- Size and place erosion protection as needed for design storm velocity and slope stabilization.
- Overflow structure required and shall be sized for the 100-yr. discharge, or design report shall demonstrate the basin retains the 100-yr., 24-hr. contributing runoff.
- Consider a sediment trap at concentrated inflows.
- Place plants according to elevation zone and inundation zone. Do not place plants where inlet(s) or overflow will be impacted.
- Include an irrigation system for plant establishment.

### MAINTENANCE

- Inspect after storms > 0.25-inches; recommend a minimum of two inspections per year.
- Remove debris, trash, and accumulated sediment. The accumulated sediment should be removed if it reduces the basin capacity.
- Check for and repair erosion issues.
- Add and redistribute organic mulch as needed.
- Prune and replace plants as needed.
- Leave organic debris in place to biodegrade.
- Remove invasive species.



WHERE TO USE	
✓	Urban Type Road
✓	Rural Type Road
✓	Streetside
✓	Parking
✓	Residential Development
✓	Commercial/Institutional Development

FUNCTIONS WITH		
 CURB OPENING	 BIOSWALE	 DEPRESSED MEDIAN
 INFILTRATION TRENCH	 OUTLET CONTROL STRUCTURE	 PERMEABLE PAVEMENT

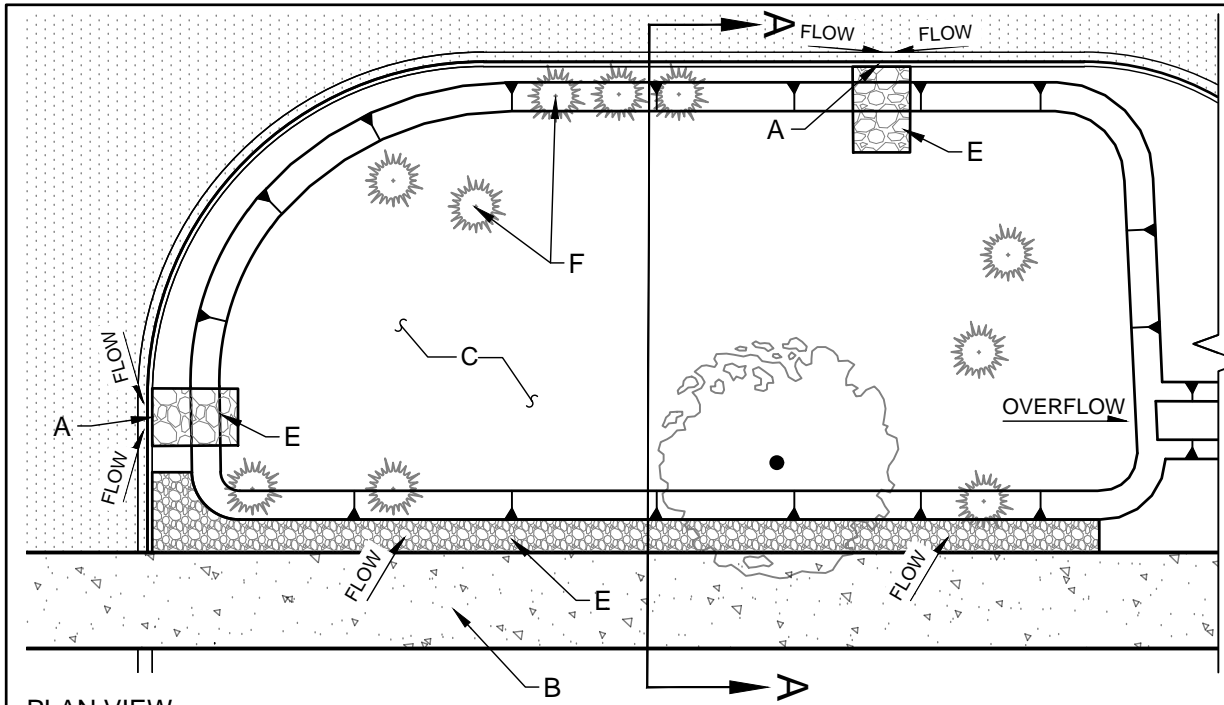

**PLAN VIEW**

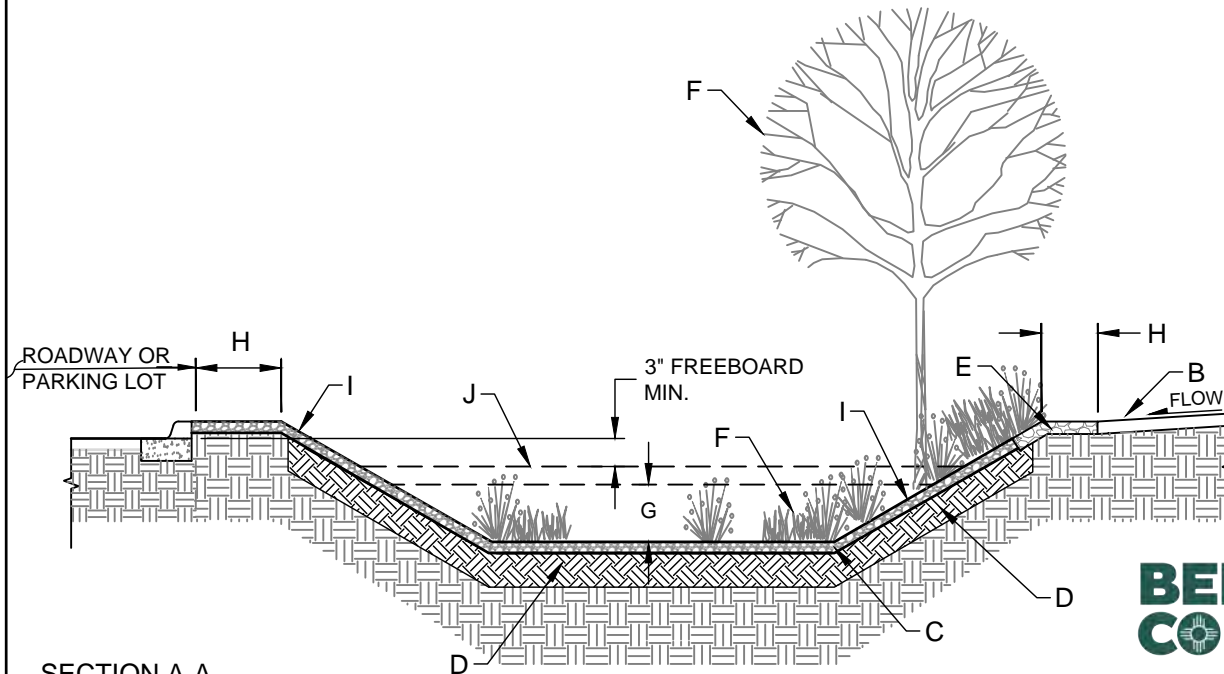

**SECTION A-A**

**GENERAL NOTES:**

1. SEE TECHNICAL GUIDANCE SHEET FOR DESIGN GUIDANCE AND CONSIDERATIONS.
2. OVERFLOW REQUIRED & SHALL BE SIZED FOR 100-YEAR PEAK DISCHARGE OR DESIGN REPORT SHALL DEMONSTRATE BASIN RETAINS 100-YEAR, 24-HOUR CONTRIBUTING RUNOFF.
3. NO PLANTINGS IMPACTING FLOW CAPACITY SHALL BE PLACED AT CONCENTRATED FLOW INLETS OR OVERFLOW.
4. TREES AND SHRUBS SHOULD BE LOCATED IN ACCORDANCE WITH INUNDATION ZONE AND ELEVATION ZONE. SEE BERNALILLO COUNTY GSI PLANT LIST FOR GUIDANCE.
5. MULCH TYPE AND LOCATION PER PROJECT PLANS SHALL BE INFORMED BY EVALUATION OF HYDRAULIC CONDITIONS AND MAY BE USED FOR EROSION PREVENTION, SLOPE STABILIZATION, OR DESIGN PREFERENCE. ORGANIC MULCH MAY BE USED WHERE DESIGN VELOCITY IS LESS THAN 1 FPS.
6. AVOID COMPACTION OF BASIN BOTTOM DURING AND AFTER CONSTRUCTION TO MAINTAIN INFILTRATION RATE

**CONSTRUCTION NOTES:**

- A. CURB OPENING PER COUNTY STD DWG GSI-01.
- B. SIDEWALK, PATH, OR OTHER HARDSCAPE DRAINING TO BASIN.
- C. ORGANIC OR INORGANIC MULCH PER PROJECT PLANS. PLANS SHALL SPECIFY MULCH TYPE, THICKNESS, AND LOCATION.
- D. SCARIFY SUBGRADE TO DEPTH OF 12", MIN.
- E. EROSION PROTECTION AT FLOW INLET. TYPE & DIMENSIONS PER PROJECT PLANS. COMPACT SUBGRADE BELOW EROSION PROTECTION TO 95% OF MAX DENSITY.
- F. PLANTS PER PROJECT PLANS.
- G. 9" MAXIMUM PONDING DEPTH & DEPTH FOR CALCULATING STORMWATER QUALITY VOLUME (SWQV). MEASURED FROM BASIN BOTTOM TO OVERFLOW ELEVATION.
- H. 2' STEP OUT WHEN BASIN ALONG ROADWAY. 1' SETBACK ALONG OTHER PEDESTRIAN ROUTES.
- I. 3H:1V SIDE SLOPE OR FLATTER TYP.
- J. WATER SURFACE AT 100-YEAR OVERFLOW DEPTH. FREEBOARD MEASURED FROM OVERFLOW WATER SURFACE TO TOP OF BASIN OR LOWEST INFLOW ELEVATION (WHICHEVER IS LOWEST).



REVISIONS

COUNTY OF BERNALILLO	
STORMWATER HARVESTING BASIN	
GSI-02	JULY 2022

# STORMWATER BUMPOUT



An area for infiltration and green infrastructure interventions created when the curb and gutter are moved out into the portion of the roadway normally reserved for parking. Otherwise known as 'bulbouts' or 'chicanes.'

## STORMWATER BUMPOUT

### DESIGN CONSIDERATIONS



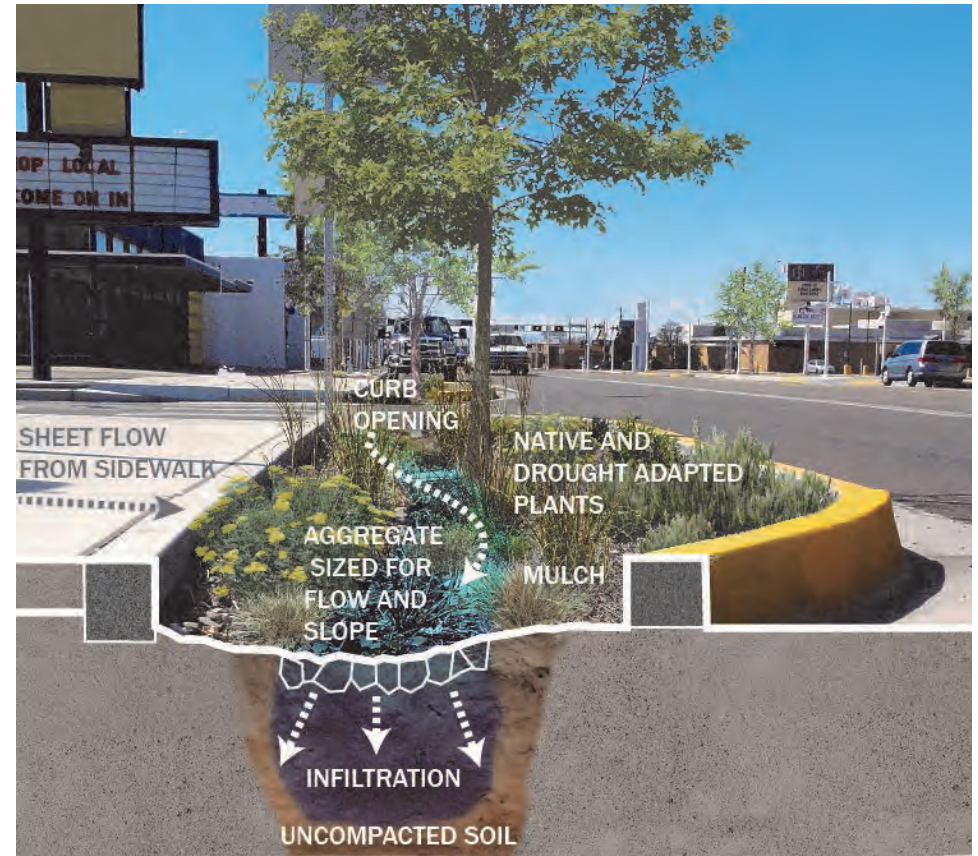

- Can be used to retrofit existing projects, as well as can be constructed with new projects. Retrofit application will require sawcut and removal of existing curb, gutter, and pavement.
- Stormwater bumpouts can function as mid-block traffic calming structures.
- To maximize infiltration, do not compact bottom during or after construction and ensure that the bottom is scarified per the standard drawing.
- Place sediment trap at inlet as shown in curb opening GSI-01 standard drawing.
- Size and place erosion protection as needed for design storm velocity.
- Place plants according to elevation zone and inundation zone. Do not place plants where inlet(s) or outlet will be impacted.
- Include an irrigation system for plant establishment.
- Select plants that allow for vehicle clearances and sight triangles.
- Utilize the AASHTO Roadside Design Guide when placing and designing stormwater bumpouts adjacent to travel ways.

### MAINTENANCE

- Inspect after storms > 0.25-inches; recommend a minimum of two inspections per year.
- Remove debris, trash, and accumulated sediment. The accumulated sediment should be removed if it reduces the bumpout capacity.
- Check for and repair erosion issues.
- Add and redistribute organic mulch as needed.
- Prune and replace plants as needed. Prune plants to maintain vehicle clearances and sight triangles.
- Leave organic debris in place to biodegrade.
- Remove invasive species.



WHERE TO USE	
<input checked="" type="checkbox"/>	Urban Type Road
<input checked="" type="checkbox"/>	Rural Type Road
<input checked="" type="checkbox"/>	Streetside
<input checked="" type="checkbox"/>	Parking
<input type="checkbox"/>	Residential Development
<input checked="" type="checkbox"/>	Commercial/Institutional Development

FUNCTIONS WITH		
		
CURB OPENING	INFILTRATION TRENCH	CHECK DAM
		
OUTLET CONTROL STRUCTURE	PERMEABLE PAVEMENT	

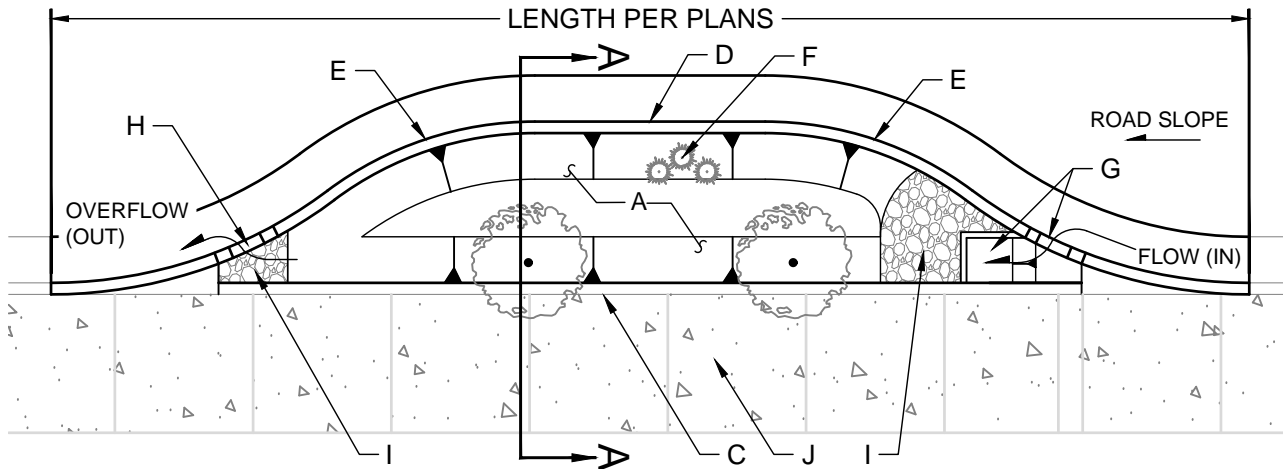

PLAN VIEW

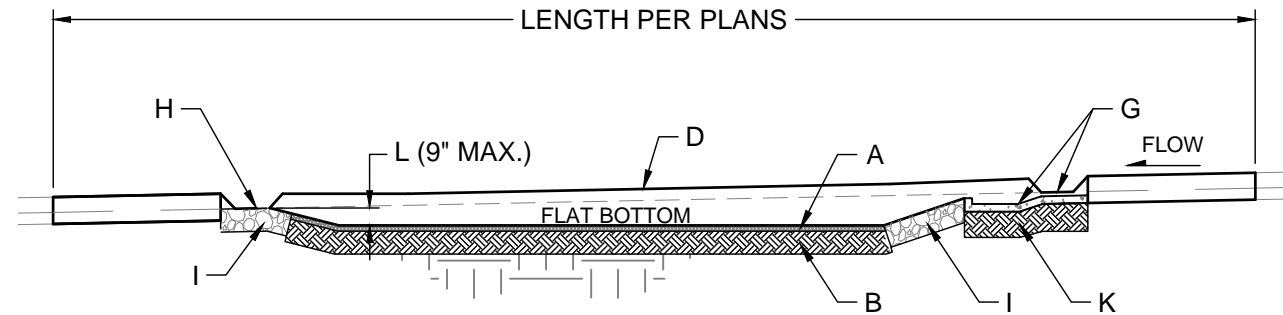

PROFILE VIEW

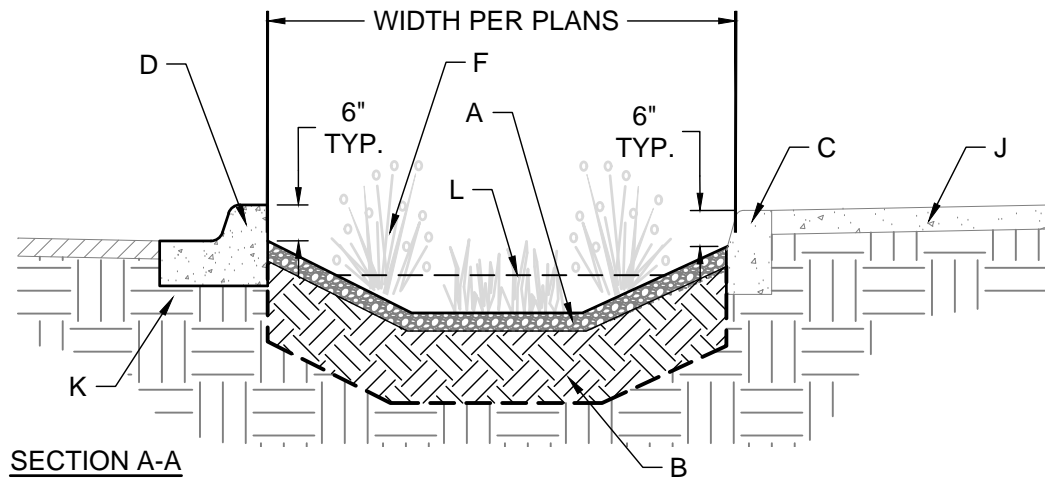

SECTION A-A

GENERAL NOTES:

1. SEE TECHNICAL GUIDANCE SHEET FOR DESIGN GUIDANCE AND CONSIDERATIONS.
2. PLANTS SHOULD BE LOCATED IN ACCORDANCE WITH INUNDATION ZONE AND ELEVATION ZONE. SEE BERNALILLO COUNTY GSI PLANT LIST FOR GUIDANCE.
3. MULCH TYPE AND LOCATION PER PROJECT PLANS SHALL BE INFORMED BY EVALUATION OF HYDRAULIC CONDITIONS AND MAY BE USED FOR EROSION PREVENTION, SLOPE STABILIZATION, OR DESIGN PREFERENCE. ORGANIC MULCH MAY BE USED WHERE DESIGN VELOCITY IS LESS THAN 1 FPS.

CONSTRUCTION NOTES:

- A. ORGANIC OR INORGANIC MULCH PER PROJECT PLANS. PLANS SHALL SPECIFY MULCH TYPE, THICKNESS, AND LOCATION.
- B. SCARIFY SUBGRADE TO DEPTH OF 12", MIN.
- C. HEADER CURB OR EXISTING CURB (SAWCUT AND REMOVE GUTTER PAN FLUSH WITH CURB FACE).
- D. STANDARD CURB AND GUTTER PER COUNTY STANDARD DRAWING 2415A.
- E. RADIUS PER PROJECT PLANS, 10' MIN.
- F. PLANTS PER PROJECT PLANS.
- G. CURB OPENING AND SEDIMENT TRAP PER COUNTY STD DWG GSI-01.
- H. CURB OPENING AT OVERFLOW PER COUNTY STD DWG GSI-01 (NO SEDIMENT TRAP).
- I. RIPRAP EROSION PROTECTION. COMPACT SUBGRADE BELOW EROSION PROTECTION TO 95% OF MAX DENSITY. REFER TO PROJECT PLANS FOR DIMENSIONS.
- J. SIDEWALK AT BACK OF CURB.
- K. COMPACTED SUBGRADE BELOW C&G AND PAVEMENT.
- L. 9" MAXIMUM PONDING DEPTH & DEPTH FOR CALCULATING STORMWATER QUALITY VOLUME (SWQV). MEASURED FROM BASIN BOTTOM TO OVERFLOW ELEVATION.



		COUNTY OF BERNALILLO	
REVISIONS		STORMWATER BUMPOUT	
		GSI-03	JULY 2022



# BIOSWALE



## BIOSWALE

A shallow, linear, or curvilinear feature designed to improve water quality by conveying, slowing, and treating runoff; allows pollutants to settle out and promotes infiltration.

### DESIGN CONSIDERATIONS





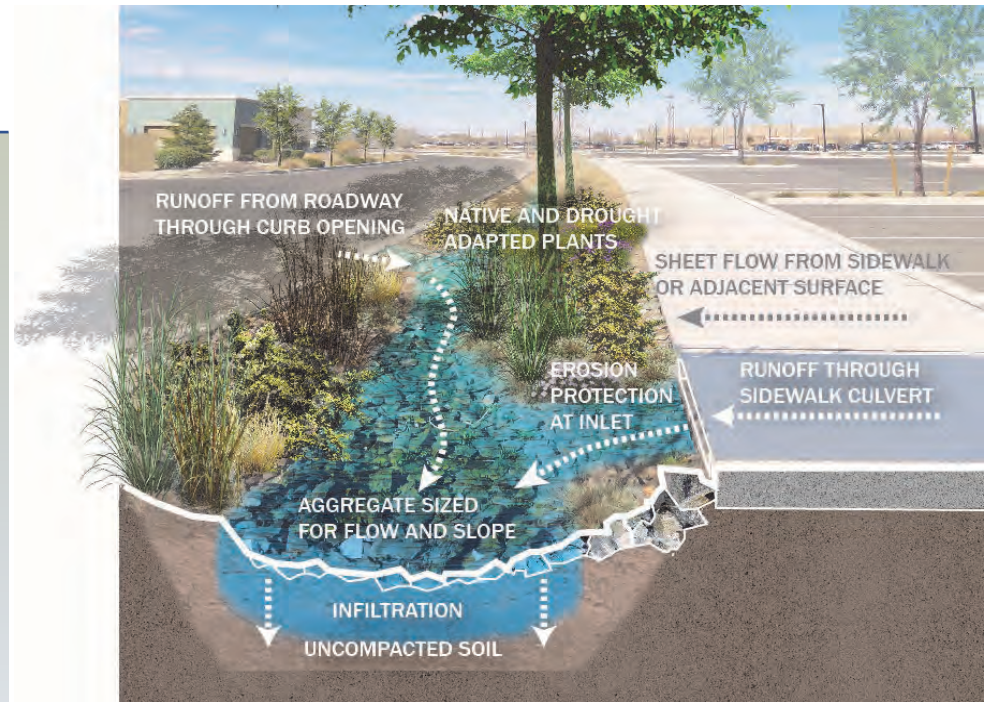

- Meandering swale design encouraged.
- Consider depth to the groundwater table and bedrock; refer to Section 6, General Design Principles.
- Recommend infiltration rate greater than 0.5-inch/hr. An underdrain may be required if the infiltration rate is less than 0.5-inch/hr.
- To maximize infiltration, do not compact bottom during or after construction and ensure that the bottom is scarified per the standard drawing.
- Size and place erosion protection as needed for design storm velocity and slope stabilization.
- Recommend max. longitudinal slope of 5% to minimize potential for erosive flow velocities.
- Consider a sediment trap at concentrated inflows.
- Place plants according to elevation zone and inundation zone. Do not place plants where inlet(s) or outlet will be impacted.
- Include an irrigation system for plant establishment.

### MAINTENANCE

- Inspect after storms > 0.25-inches; recommend a minimum of two inspections per year.
- Remove debris, trash, and accumulated sediment. The accumulated sediment should be removed if it reduces the bioswale capacity.
- Check for and repair erosion issues.
- Add and redistribute organic mulch as needed.
- Prune and replace plants as needed.
- Leave organic debris in place to biodegrade.
- Remove invasive species.



WHERE TO USE	
<input checked="" type="checkbox"/>	Urban Type Road
<input checked="" type="checkbox"/>	Rural Type Road
<input checked="" type="checkbox"/>	Streetside
<input checked="" type="checkbox"/>	Parking
<input checked="" type="checkbox"/>	Residential Development
<input checked="" type="checkbox"/>	Commercial/Institutional Development

FUNCTIONS WITH		
		
CURB OPENING	STORMWATER BASIN	DEPRESSED MEDIAN
		
INFILTRATION TRENCH	CHECK DAM	OUTLET CONTROL STRUCTURE

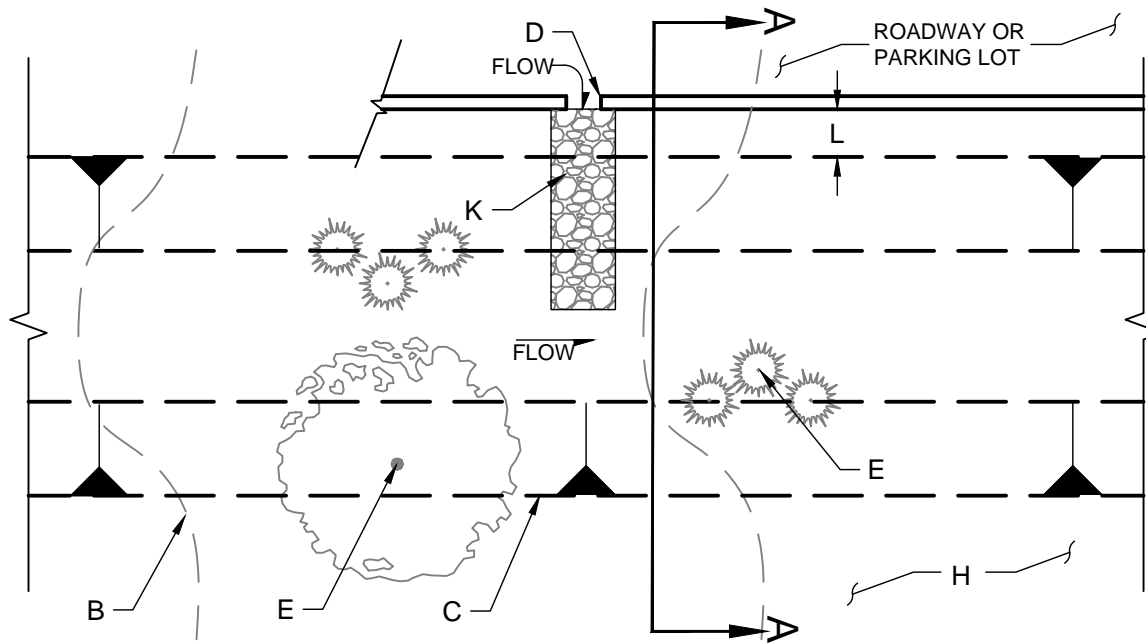

**PLAN VIEW**

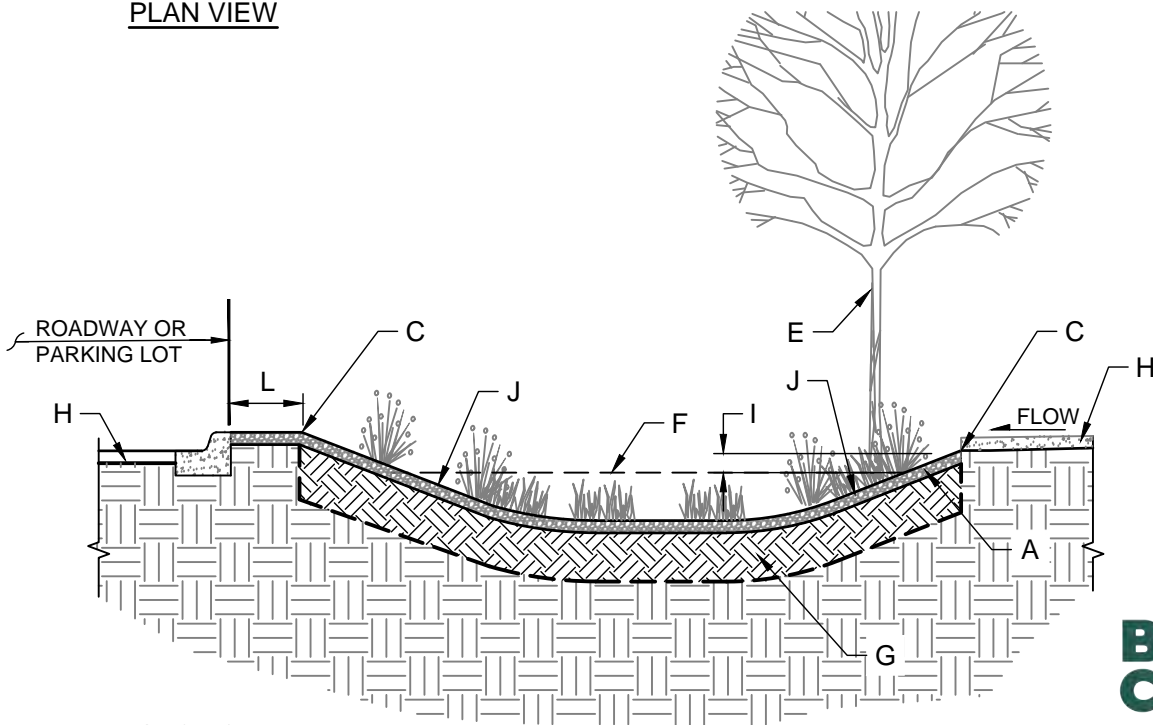

**SECTION A-A**

**GENERAL NOTES:**

1. SEE TECHNICAL GUIDANCE SHEET FOR DESIGN GUIDANCE AND CONSIDERATIONS.
2. TREES AND SHRUBS SHOULD BE LOCATED IN ACCORDANCE WITH INUNDATION ZONE AND ELEVATION ZONE. SEE BERNALILLO COUNTY GSI PLANT LIST FOR GUIDANCE.
3. CHECK DAMS PER COUNTY STD DWG GSI-07 SHALL BE PROVIDED WHEN DESIGN STORM VELOCITY EXCEEDS 3 FPS. REFER TO PROJECT PLANS.
4. MULCH TYPE AND LOCATION PER PROJECT PLANS SHALL BE INFORMED BY EVALUATION OF HYDRAULIC CONDITIONS AND MAY BE USED FOR EROSION PREVENTION, SLOPE STABILIZATION, OR DESIGN PREFERENCE. ORGANIC MULCH MAY BE USED WHERE DESIGN VELOCITY IS LESS THAN 1 FPS.
5. STABLE GRASS LINING MAY BE USED IN PLACE OF MULCH PER PROJECT PLANS.
6. AVOID COMPACTION OF BIOSWALE BOTTOM DURING AND AFTER CONSTRUCTION TO MAINTAIN INFILTRATION RATE.

**CONSTRUCTION NOTES:**

- A. ORGANIC OR INORGANIC MULCH PER PROJECT PLANS. PLANS SHALL SPECIFY MULCH TYPE, THICKNESS, AND LOCATION.
- B. CONCEPTUAL DESIGN CONTOUR.
- C. TOP OF BIOSWALE/CHANNEL/DITCH.
- D. CURB OPENING PER COUNTY STD DWG GSI-01.
- E. PLANTS PER PROJECT PLANS.
- F. WATER SURFACE AT DESIGN STORM FLOW DEPTH
- G. SCARIFY SUBGRADE TO DEPTH OF 12", MIN.
- H. ADJACENT SURFACES MAY VARY.
- I. 3" FREEBOARD, MIN.
- J. 3H:1V SIDE SLOPE OR FLATTER, TYP.
- K. EROSION PROTECTION AT FLOW INLET. COMPACT SUBGRADE BELOW EROSION PROTECTION TO 95% OF MAX DENSITY. REFER TO PROJECT PLANS FOR DIMENSIONS AND DETAILS.
- L. 2' STEP OUT WHEN BIOSWALE ALONG ROADWAY. 1' SETBACK ALONG OTHER PEDESTRIAN ROUTES. CROSS SLOPE SHALL MATCH SHOULDER OR 2% MAX.



		COUNTY OF BERNALILLO	
REVISIONS		BIOSWALE	
		GSI-04	JULY 2022

# DEPRESSED MEDIAN



A linear or curvilinear shallow depression located in the roadway median designed to improve water quality by conveying, slowing, and treating runoff; allows pollutants to settle out and promotes infiltration.

## DEPRESSED MEDIAN

### DESIGN CONSIDERATIONS



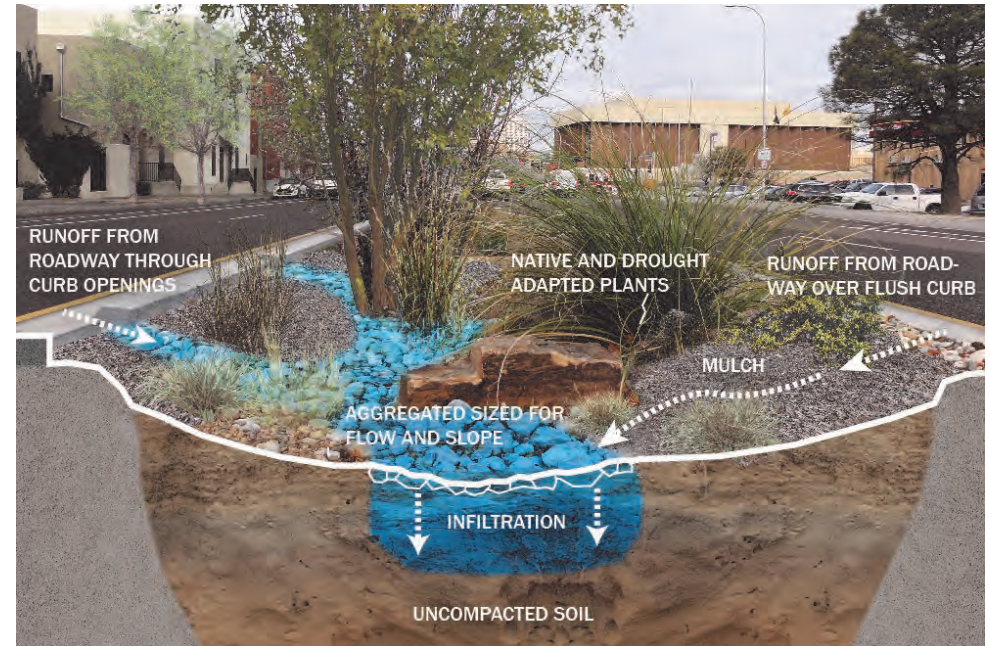

- Consider depth to the groundwater table and bedrock; refer to Section 6, General Design Principles.
- Recommend max. longitudinal slope of 5% to minimize potential for erosive flow velocities.
- Recommend infiltration rate greater than 0.5-inch/hr. An underdrain may be required if the infiltration rate is less than 0.5-inch/hr.
- To maximize infiltration, do not compact bottom during or after construction and ensure that the bottom is scarified per the standard drawing.
- Size and place erosion protection as needed for design storm velocity and slope stabilization.
- Consider a sediment trap at concentrated inflows.
- Place plants according to elevation zone and inundation zone. Do not place plants where inlet(s) or outlet will be impacted.
- Include an irrigation system for plant establishment.
- Select plants that allow for vehicle clearances and sight triangles.
- Utilize the AASHTO Roadside Design Guide when placing and designing depressed medians adjacent to travel ways.

### MAINTENANCE

- Inspect after storms > 0.25-inches; recommend a minimum of two inspections per year.
- Remove debris, trash, and accumulated sediment. The accumulated sediment should be removed if it reduces the median capacity.
- Check for and repair erosion issues.
- Add and redistribute erosion protection as needed.
- Prune and replace plants as needed. Prune plants to maintain vehicle clearances and sight triangles.
- Leave organic debris in place to biodegrade.
- Remove invasive species.



WHERE TO USE	
✓	Urban Type Road
✓	Rural Type Road
✓	Streetside
✓	Parking
✓	Residential Development
✓	Commercial/Institutional Development

FUNCTIONS WITH		
 CURB OPENING	 STORMWATER BASIN	 BIOSWALE
 CHECK DAM	 OUTLET CONTROL STRUCTURE	

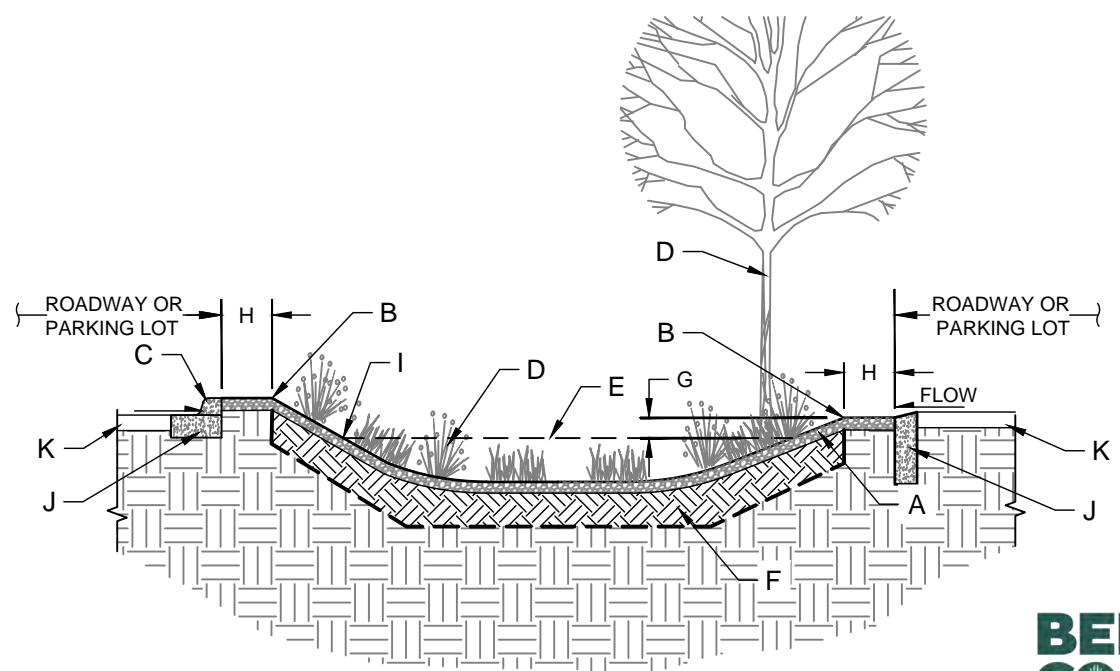
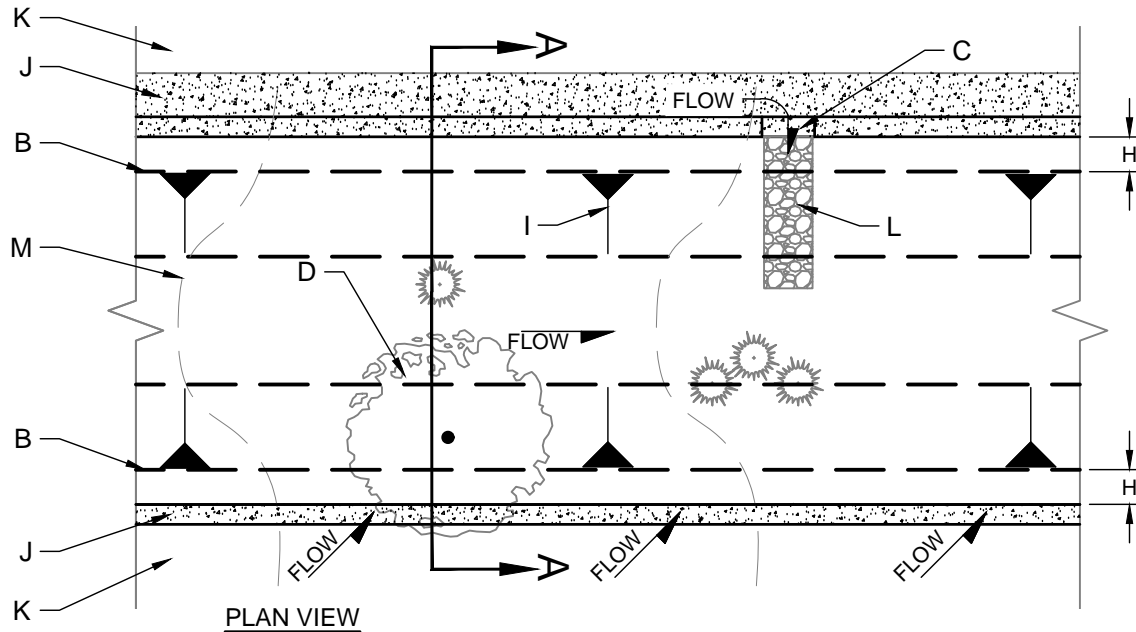

**GENERAL NOTES:**

1. SEE TECHNICAL GUIDANCE SHEET FOR DESIGN GUIDANCE AND CONSIDERATIONS.
2. TREES AND SHRUBS SHOULD BE LOCATED IN ACCORDANCE WITH INUNDATION ZONE AND ELEVATION ZONE. SEE BERNALILLO COUNTY GSI PLANT LIST FOR GUIDANCE.
3. CROSS SLOPE OF SHOULDER BEHIND FLUSH CURB SHOULD BE STEEPER THAN LONGITUDINAL SLOPE TO DIRECT FLOW TO DEPRESSED MEDIAN.
4. CHECK DAMS PER COUNTY STD DWG GSI-07 SHALL BE PROVIDED WHEN DESIGN STORM VELOCITY EXCEEDS 3.0 FPS. REFER TO PROJECT PLANS.
5. MULCH TYPE AND LOCATION PER PROJECT PLANS SHALL BE INFORMED BY EVALUATION OF HYDRAULIC CONDITIONS AND MAY BE USED FOR EROSION PREVENTION, SLOPE STABILIZATION, OR DESIGN PREFERENCE. ORGANIC MULCH MAY BE USED WHERE DESIGN VELOCITY IS LESS THAN 1 FPS.

**CONSTRUCTION NOTES:**

- A. ORGANIC OR INORGANIC MULCH PER PROJECT PLANS. PLANS SHALL SPECIFY MULCH TYPE, THICKNESS, AND LOCATION.
- B. TOP OF BIOSWALE/CHANNEL/DITCH.
- C. CURB OPENING PER COUNTY STD DWG GSI-01.
- D. PLANTS PER PROJECT PLANS.
- E. WATER SURFACE AT DESIGN STORM FLOW DEPTH.
- F. SCARIFY SUBGRADE TO DEPTH OF 12", MIN.
- G. 3" FREEBOARD, MIN.
- H. 2' STEP OUT WHEN USED ALONG ROADWAY. 1' SETBACK ALONG OTHER PEDESTRIAN ROUTES. CROSS SLOPE PER PROJECT PLANS.
- I. 3H:1V SIDE SLOPE OR FLATTER, TYP.
- J. CONCRETE STANDARD CURB AND GUTTER OR FLUSH HEADER CURB PER COUNTY STANDARD DWG 2415A/B. REFER TO PROJECT PLANS.
- K. ADJACENT PARKING/ROAD SURFACES.
- L. EROSION PROTECTION AT FLOW INLET. COMPACT SUBGRADE BELOW EROSION PROTECTION TO 95% OF MAX DENSITY. REFER TO PROJECT PLANS FOR DIMENSIONS AND DETAILS.
- M. CONCEPTUAL DESIGN CONTOUR.



REVISIONS	COUNTY OF BERNALILLO
	DEPRESSED MEDIAN
	GSI-05
	JULY 2022

# INFILTRATION TRENCH



A linear excavated area that is lined with filter fabric and filled with rock in order to create additional space for runoff to collect and infiltrate into adjacent permeable soils.

## INFILTRATION TRENCH

### DESIGN CONSIDERATIONS

- Recommend using where soils have low infiltration rates or where there is limited width for implementing GSI BMPs.
- Recommend stormwater runoff pretreatment (filter strips, sediment traps, etc.) to prevent sediment from clogging the infiltration trench.
- Porous gravel material provides additional retention capacity prior to infiltration into the subsurface.
- Consider depth to the groundwater table and bedrock; refer to Section 6, General Design Principles.
- Recommend infiltration rate greater than 0.5-inch/hr. An underdrain may be required if the infiltration rate is less than 0.5-inch/hr.
- To maximize infiltration, do not compact bottom during or after construction and ensure that the bottom is scarified per the standard drawing.
- Vegetation may not be grown on the infiltration trench. Plantings adjacent to the infiltration trench are encouraged so vegetation may utilize the infiltrated stormwater; plants should not inhibit maintenance of the infiltration trench.

### MAINTENANCE

- Inspect after storms > 0.25-inches; recommend a minimum of two inspections per year.
- Remove debris, trash, and accumulated sediment, especially at pretreatment locations.
- Prune and replace adjacent plants as needed.
- Remove plants from trench. Vegetation within the trench can reduce the infiltration.
- If infiltration rates have decreased substantially, major maintenance may be performed by removing, cleaning, and replacing the top gravel layer or by removing the gravel and replacing any clogged filter fabric.

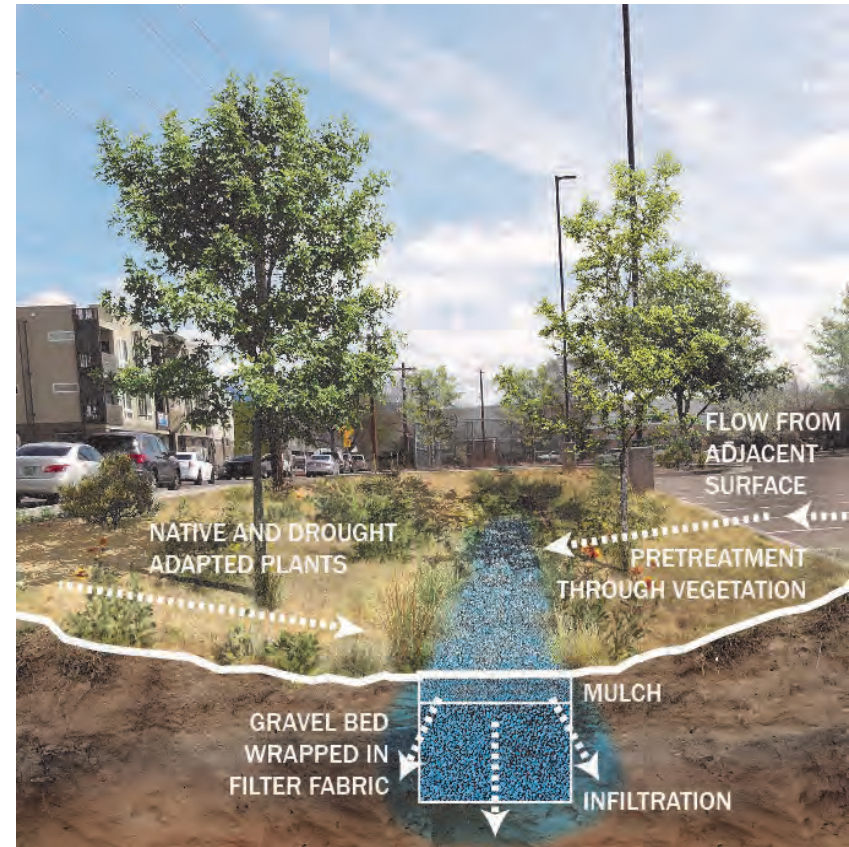

WHERE TO USE	
✓	Urban Type Road
✓	Rural Type Road
✓	Streetside
✓	Parking
✓	Residential Development
✓	Commercial/Institutional Development

FUNCTIONS WITH		
CURB OPENING	STORMWATER BASIN	STORMWATER BUMPOUT
BIOSWALE	PERMEABLE PAVEMENT	

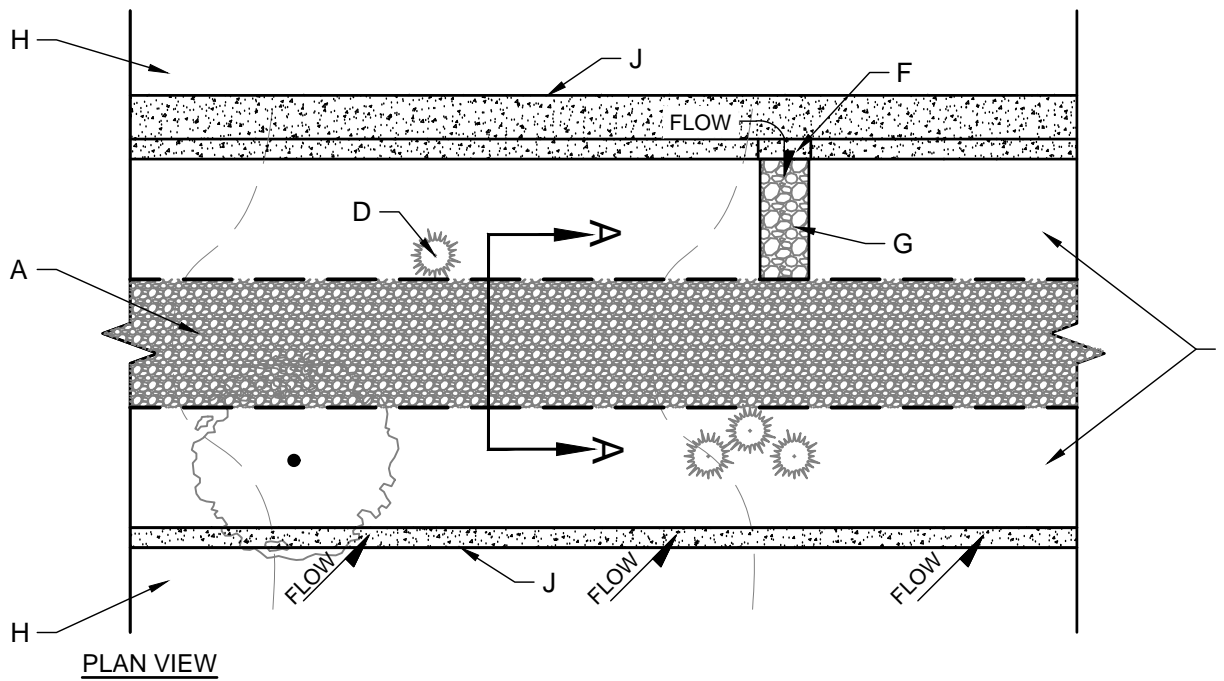

**GENERAL NOTES:**

1. SEE TECHNICAL GUIDANCE SHEET FOR DESIGN GUIDANCE AND CONSIDERATIONS.
2. RESERVOIR LAYER WIDTH AND DEPTH SHALL BE PROVIDED ON PROJECT PLANS. CONSIDER IN-SITU SUBSURFACE CONDITIONS AND OTHER SITE CONSTRAINTS.
3. ALL STONE SHALL BE DOUBLE-WASHED, SUFFICIENT TO REMOVE DUST AND OTHER COATINGS.

**CONSTRUCTION NOTES:**

- A. FILTER LAYER, CLEAN GRAVEL PER PROJECT PLANS. 3" THICK MINIMUM.
- B. RESERVOIR LAYER, ASTM #2 OR AS SPECIFIED ON PROJECT PLANS.
- C. NON-WOVEN GEOTEXTILE FILTER CLOTH AROUND GRAVEL RESERVOIR LAYER, ALL SIDES (INCLUDING BETWEEN RESERVOIR LAYER AND FILTER LAYER).
- D. PLANTS PER PROJECT PLANS.
- E. SCARIFY SUBGRADE BELOW RESERVOIR LAYER TO DEPTH OF 12", MIN.
- F. CURB OPENING PER COUNTY STD DWG GSI-01.
- G. EROSION PROTECTION AT FLOW INLET. COMPACT SUBGRADE BELOW EROSION PROTECTION TO 95% OF MAX DENSITY. REFER TO PROJECT PLANS FOR DIMENSIONS AND DETAILS.
- H. ADJACENT PARKING/ROAD/ HARDSCAPE SURFACES.
- I. ORGANIC OR INORGANIC MULCH PER PROJECT PLANS. PLANS SHALL SPECIFY MULCH TYPE, THICKNESS, AND LOCATION.
- J. CURB OR CURB AND GUTTER PER PROJECT PLANS.

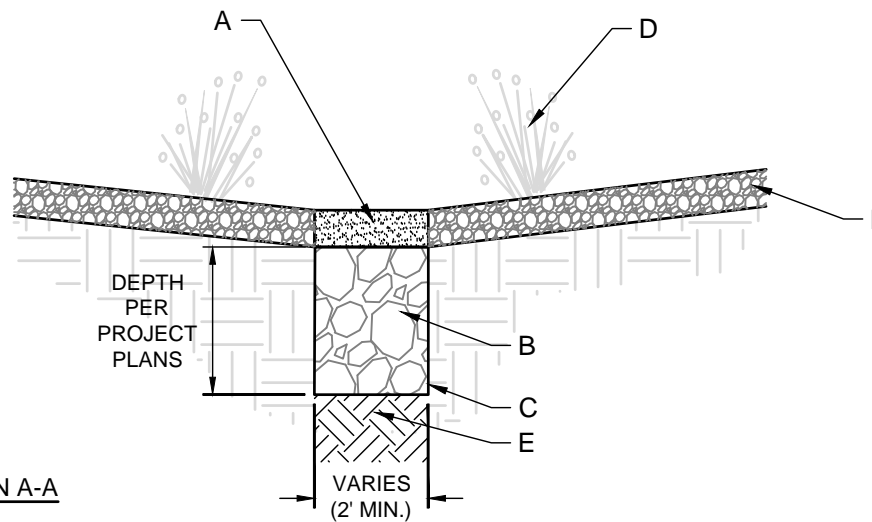

**SECTION A-A**



		COUNTY OF BERNALILLO	
REVISIONS		INFILTRATION TRENCH	
		GSI-06	JULY 2022

# CHECK DAM



A shallow, typically permeable control placed perpendicular to the flow of water within a drainage feature that slows the flow, increasing infiltration as well as retaining sediment and debris.

## CHECK DAM

### DESIGN CONSIDERATIONS



- Check dams shall be installed when the design storm velocity exceeds 3 feet-per-second (fps).
- Most effective when used in series, spaced at regular intervals.
- Recommend check dam max. height of 18-inches.
- Recommend max. longitudinal slope of 5% to minimize potential for erosive flow velocities.
- Check dams can be comprised of angular gravel or stone or other aggregates, such as clean broken concrete, wood, metal, or compacted soil. The standard drawing is specific to gravel, cobble, clean broken concrete, or other suitable aggregate; if other materials are used, the design will vary from the standard drawing.
- Size and place check dam materials as needed for the design storm velocity and slope stabilization per project plans. Typically constructed of 8-12-inch rock and may be graded such that smaller diameter rock is located on the upstream side of larger rock.
- This standard drawing is for a shallow, permeable, rock check dam designed for smaller flows, typical for GSI/LID BMPs. Larger structures designed for larger flows or steeper slopes could use wire-tied rip rap or concrete.

### MAINTENANCE

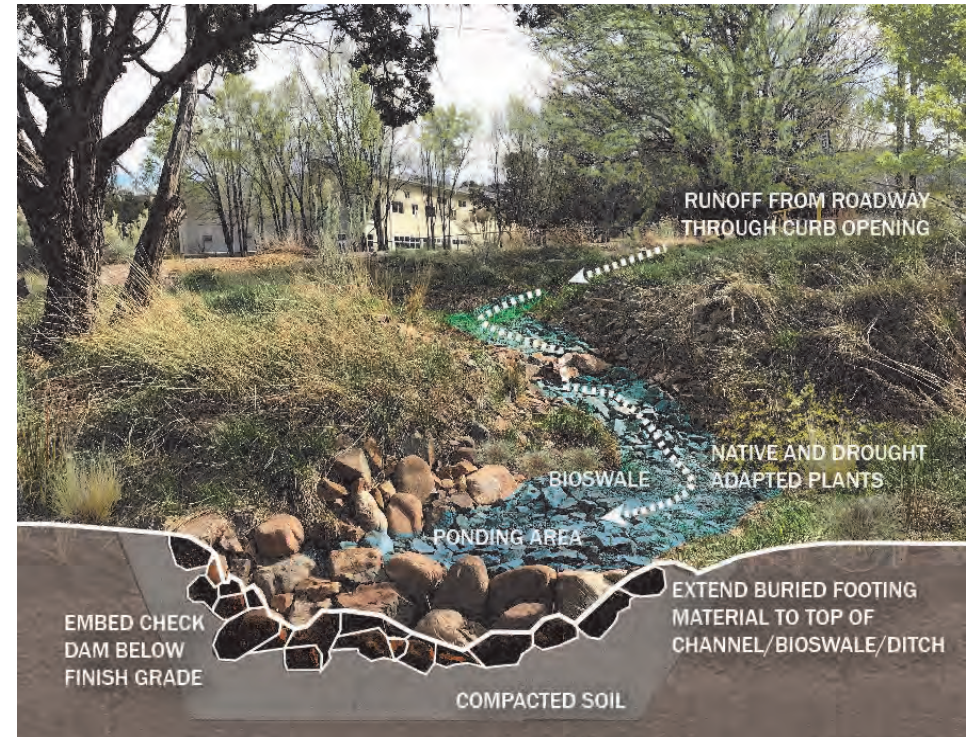
- Inspect after storms > 0.25-inches; recommend a minimum of two inspections per year.
- Remove debris, trash, and accumulated sediment. Remove sediment if over half of the original check dam height.
- Check for and repair erosion issues; look for flanking and scour issues.
- Restore dislodged or washed out check dams to their original configuration.
- Remove invasive species and vegetation growing near the check dam whose roots could damage the structure.

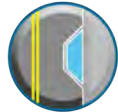

WHERE TO USE	
✓	Urban Type Road
✓	Rural Type Road
✓	Streetside
✓	Parking
✓	Residential Development
✓	Commercial/Institutional Development

FUNCTIONS WITH		
		
STORMWATER BUMPOUT	BIOSWALE	DEPRESSED MEDIAN

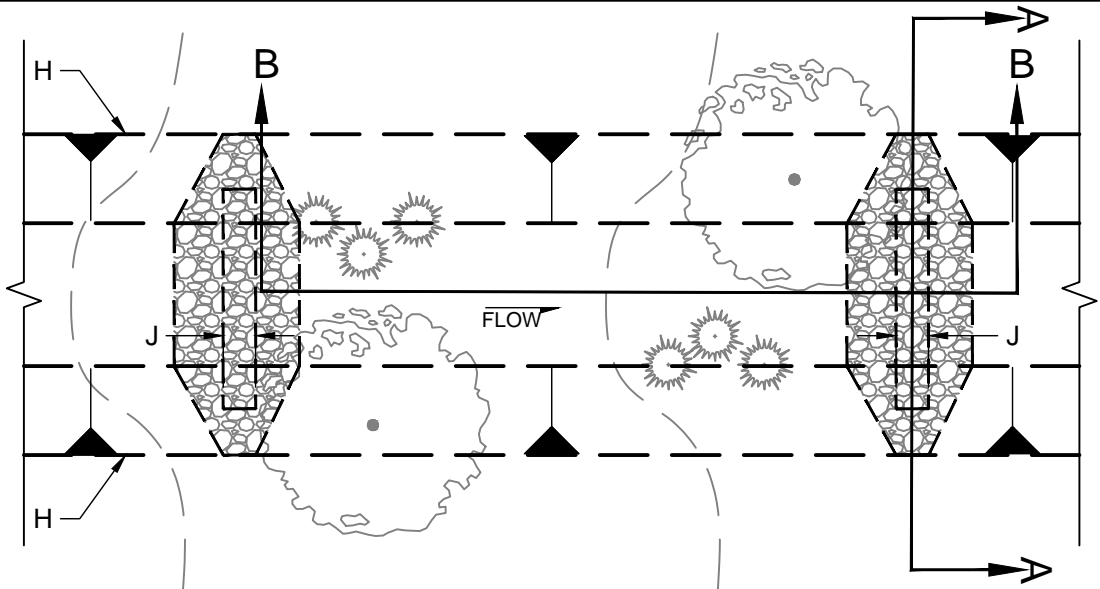

PLAN VIEW

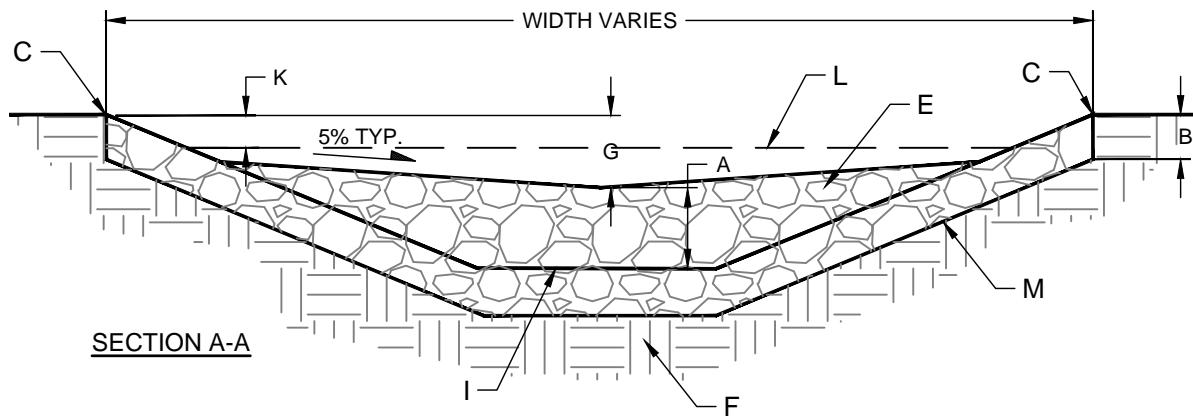

SECTION A-A

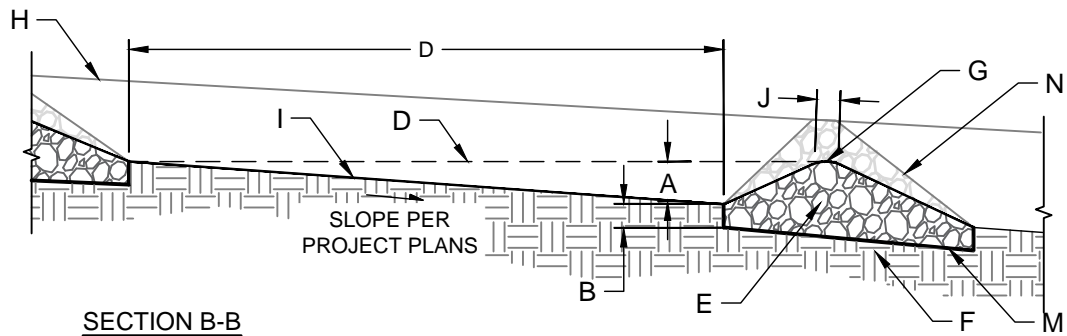

SECTION B-B

**GENERAL NOTES:**

1. SEE TECHNICAL GUIDANCE SHEET FOR DESIGN GUIDANCE AND CONSIDERATIONS, INCLUDING DISCUSSION OF OTHER ALLOWABLE MATERIALS.

**CONSTRUCTION NOTES:**

- A. HEIGHT PER PROJECT PLANS.
- B. CHECK DAM EMBEDDED BELOW FINISHED GRADE, 6" MIN.
- C. EXTEND CHECK DAM TO TOP OF CHANNEL/BIOSWALE/DITCH TO PREVENT FROM BEING FLANKED.
- D. SPACE CHECK DAMS SUCH THAT THE DOWNSTREAM WEIR ELEVATION IS AT OR ABOVE THE TOE ELEVATION OF THE NEXT UPSTREAM WEIR.
- E. GRAVEL, COBBLE, CLEAN BROKEN CONCRETE, OR OTHER SUITABLE AGGREGATE, SIZED TO WITHSTAND DESIGN STORM FLOW CONDITIONS.
- F. COMPACT SUBGRADE BELOW CHECK DAM BASE TO 95% OF MAX DENSITY.
- G. WEIR ELEVATION, 9" (MIN) BELOW ADJACENT TOP OF BIOSWALE/CHANNEL/DITCH.
- H. TOP OF BIOSWALE/CHANNEL/DITCH.
- I. DESIGN FLOWLINE ELEVATION OF BIOSWALE/CHANNEL/DITCH.
- J. 12" WIDE SHELF, MIN.
- K. 3" FREEBOARD, MIN.
- L. WATER SURFACE AT DESIGN STORM FLOW DEPTH OVER CHECK DAM.
- M. NON-WOVEN GEOTEXTILE FILTER CLOTH BETWEEN RIPRAP AND SUBGRADE.
- N. 3H:1V SIDE SLOPE OR FLATTER, TYP.



REVISIONS	COUNTY OF BERNALILLO
	CHECK DAM
	GSI-07
	JULY 2022



# OUTLET CONTROL STRUCTURE



A structure placed at the discharge point from a BMP or detention pond designed to regulate the release of stormwater and to facilitate capture of sediment and floatables.

## OUTLET CONTROL STRUCTURE

### DESIGN CONSIDERATIONS



- Outlet control structures allow for ponding within multiple GSI BMPs and should be designed to provide an outlet for larger storm events that exceed the capacity of the BMP.
- The raised outlet structure, as well as the sump/baffle design, allow trash, debris, and sediment to drop out of the stormwater within the BMP.
- The structure should be located at the downstream end of a drainage facility, and the outfall must connect to a downstream collection system, such as a storm drain, basin, channel, or arroyo.
- Maintenance access to the outlet control structure should be considered and provided during design.

### MAINTENANCE

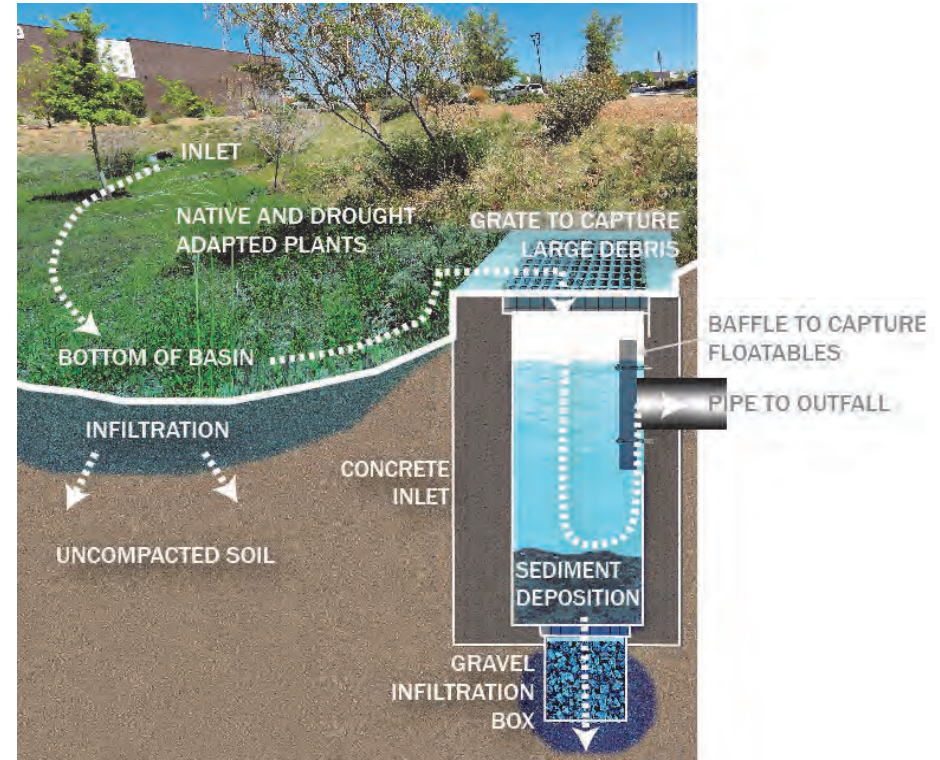
- Inspect after storms > 0.25-inches; recommend a minimum of two inspections per year.
- Remove debris, trash, and accumulated sediment from the grate and structure sump. A vacuum truck may be needed for the structure sump maintenance.
- Encroaching vegetation should be pruned or removed to maintain a min. of 2-foot landscape buffer from the structure.

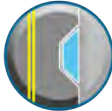

WHERE TO USE	
✓	Urban Type Road
✓	Rural Type Road
✓	Streetside
✓	Parking
✓	Residential Development
✓	Commercial/Institutional Development

FUNCTIONS WITH		
		
STORMWATER BASIN	STORMWATER BUMPOUT	BIOSWALE
		
DEPRESSED MEDIAN		

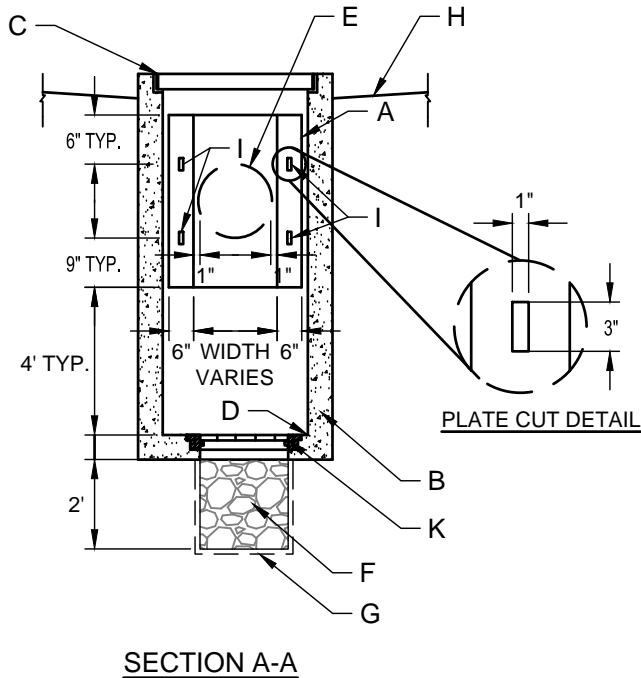
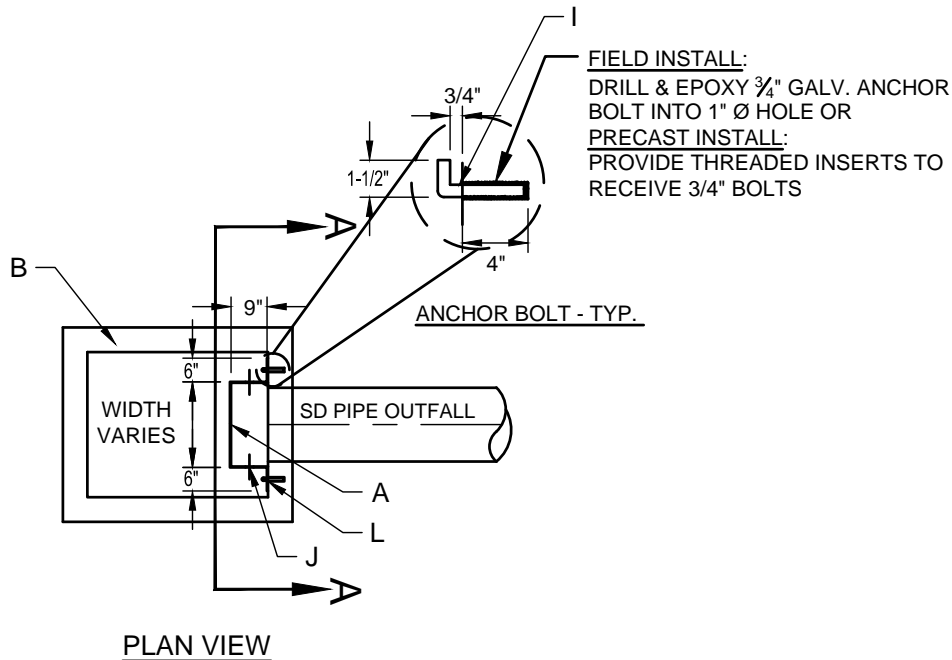

**GENERAL NOTES:**

1. SEE TECHNICAL GUIDANCE SHEET FOR DESIGN GUIDANCE AND CONSIDERATIONS.
2. OUTLET CONTROL PLATE DIMENSIONS AND INLET SUMP DEPTH SHOULD BE DESIGNED FOR CONTRIBUTING WATERSHED/SEDIMENT LOAD AND DESIGN HYDRAULIC CONDITIONS. DIMENSIONS SHOWN ARE FOR TYPICAL APPLICATION AND MAY BE MODIFIED BY PROJECT PLANS.
3. AS APPROVED BY ENGINEER, ALTERNATIVE MANUFACTURED BAFFLE MAY BE USED.

**CONSTRUCTION NOTES:**

- A. 3/16" ALUMINUM BAFFLE. WIDTH PER PLAN.
- B. CONCRETE DROP INLET. TYPE AND SIZE PER PROJECT PLANS.
- C. INLET GRATE ELEVATION PER PROJECT PLANS.
- D. INLET SUMP ELEVATION PER PROJECT PLANS.
- E. STORM DRAIN OUTFALL PIPE. SIZE AND INVERT ELEVATION PER PROJECT PLANS.
- F. GRAVEL INFILTRATION BOX, ASTM #57 STONE.
- G. NON-WOVEN GEOTEXTILE FILTER CLOTH AROUND GRAVEL, ALL SIDES.
- H. FINISHED GROUND AT INLET. ELEVATION PER PROJECT PLANS.
- I. RECTANGULAR CUT INTO PLATE TO HANG ON ANCHOR BOLT.
- J. LIFTING HOLE, BOTH SIDES OF BAFFLE. 2" DIA. HOLE CUT INTO PLATE 4.5" FROM WALL, 2" (MIN.) FROM TOP OF BAFFLE.
- K. ROUND STEEL GRATE AND FRAME (12" DIAMETER MIN.) IN BOTTOM OF INLET SUMP. GRATE TYPE/MANUFACTURER PER PROJECT PLANS.
- L. 1/8" THICK NEOPRENE WASHER AT ANCHOR BETWEEN PLATE TO CONCRETE WALL CONTACT AREA.



		COUNTY OF BERNALILLO	
REVISIONS		OUTLET CONTROL STRUCTURE	
		GSI-08	JULY 2022

# PERMEABLE PAVEMENT



Paving material that allows stormwater to move through the pavement's surface to a storage layer below, allowing infiltration into the underlying soil. Includes, but is not limited to, permeable interlocking pavers, asphalt, and concrete.

## PERMEABLE PAVEMENT

### DESIGN CONSIDERATIONS





- Other pavement types than shown on the standard drawing may be considered, such as permeable gutter systems or porous asphalt, pending approval by the County.
- Control of sediment is important to maintain pavement permeability; stormwater run-on should not be sediment laden.
- Consider concrete curb for edge support and to help keep unwanted sediment off the pavement.
- Pavement design shall address both stormwater retention, geotechnical, and structural pavement design requirements.
- Consider depth to the groundwater table and bedrock; refer to Section 6, General Design Principles.
- Recommend max. longitudinal slope of 5%. Slopes greater than 2% require subsurface check dams.

### MAINTENANCE

- Inspect after storms > 0.25-inches; recommend a minimum of two inspections per year. Watch for sediment washout or deposition on the pavement.
- Remove accumulated sediment and debris from pavement using manufacturer's recommended maintenance approach and schedule. Surficial dirt does not necessarily clog the pavement; however, dirt ground in by repeated vehicle use can lead to clogging.
- Routine and long-term maintenance, using high performance, regenerative air vacuuming to maintain the hydraulic function, are typically required. Mechanical broom type sweepers are typically not recommended.
- Pavements should not receive regular winter salt or sanding.
- Seal coating or repaving are not appropriate for permeable pavements.

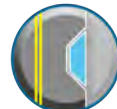

WHERE TO USE	
<input checked="" type="checkbox"/>	Urban Type Road
<input type="checkbox"/>	Rural Type Road
<input checked="" type="checkbox"/>	Streetside
<input checked="" type="checkbox"/>	Parking
<input checked="" type="checkbox"/>	Residential Development
<input checked="" type="checkbox"/>	Commercial/Institutional Development

FUNCTIONS WITH		
		
CURB OPENING	STORMWATER BASIN	STORMWATER BUMPOUT
		
INFILTRATION TRENCH		

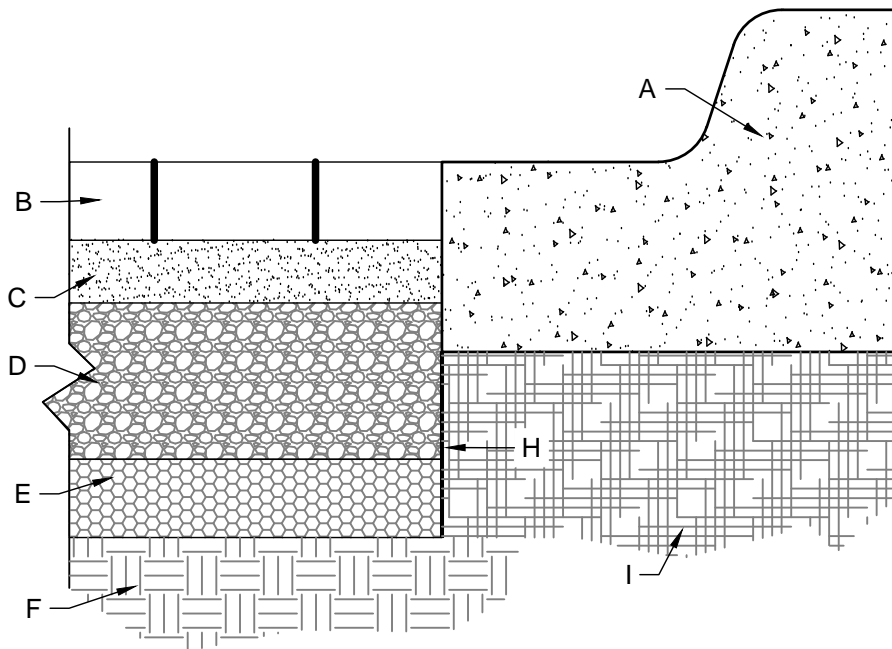

**PERMEABLE PAVERS - TYPICAL SECTION**

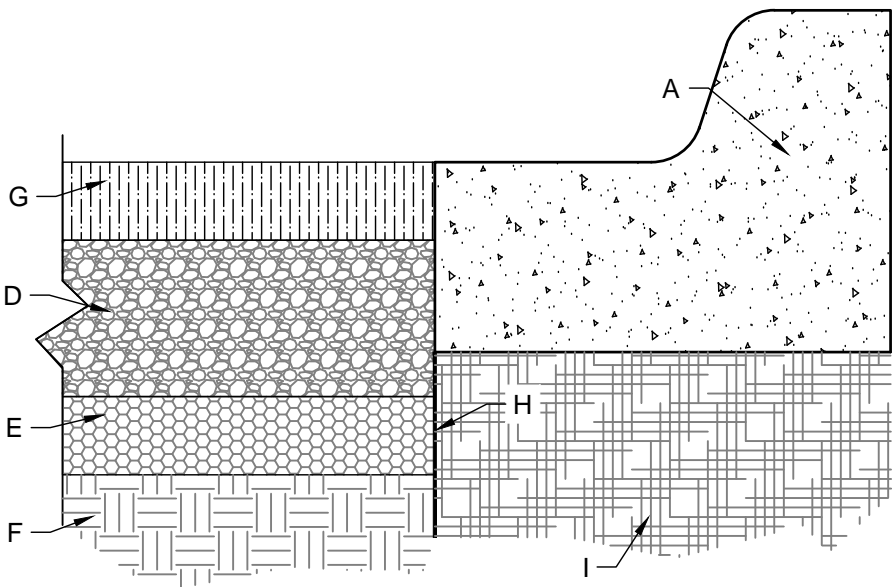

**PERVIOUS CONCRETE - TYPICAL SECTION**

**GENERAL NOTES:**

1. SEE TECHNICAL GUIDANCE SHEET FOR DESIGN GUIDANCE AND CONSIDERATIONS.
2. TYPICAL SECTIONS ARE PROVIDED FOR GENERAL GUIDANCE. LAYER DEPTHS ARE PROJECT/SITE SPECIFIC AND SHALL BE DESIGNED BASED ON GEOTECHNICAL RECOMMENDATIONS AND LOADING/STRUCTURAL REQUIREMENTS.
3. RESERVOIR LAYER THICKNESS SHALL BE PROVIDED ON PROJECT PLANS. THICKNESS SHALL BE DETERMINED BASED ON STORMWATER QUALITY VOLUME (SWQV) RETENTION REQUIREMENTS AND STRUCTURAL PAVEMENT DESIGN REQUIREMENTS.
4. SYSTEM SHALL BE DESIGNED TO DRAIN THE DESIGN STORM WITHIN 96 HOURS. UNDERDRAIN MAY BE CONSIDERED IF IN-SITU SOILS ARE NOT CONDUCTIVE TO INFILTRATION (GENERALLY LESS THAN 0.2 IN/HR).
5. BOTTOM OF RESERVOIR LAYER SHOULD BE DESIGNED AS FLAT AS POSSIBLE (0% PREFERRED). SUBSURFACE CHECK DAMS IN RESERVOIR LAYER REQUIRED IF SURFACE SLOPE EXCEEDS 2%.
6. ALL STONE SHALL BE DOUBLE-WASHED, SUFFICIENT TO REMOVE DUST AND OTHER COATINGS.
7. NON-WOVEN GEOTEXTILE FILTER FABRIC SHALL BE PLACED ON THE SIDES OF OPEN-GRADED STONE LAYERS AT THE EDGES OF SYSTEM (WHERE NO OTHER EDGE RESTRAINT PROVIDED) TO PREVENT MIGRATION OF ADJACENT FINE MATERIAL.
8. AGGREGATE SIZES IN CONSTRUCTION NOTES ARE PER ASTM D448-STANDARD CLASSIFICATION FOR SIZES OF AGGREGATE FOR ROAD AND BRIDGE CONSTRUCTION.

**CONSTRUCTION NOTES:**

- A. CONCRETE CURB OR OTHER EDGE RESTRAINT PER PROJECT STANDARD CURB AND GUTTER PER COUNTY STANDARD DRAWING 2415A SHOWN
- B. CONCRETE PAVER (MIN. THICKNESS IS 3-1/8" FOR VEHICULAR TRAFFIC, 2-3/8" FOR PEDESTRIAN AREAS). JOINTS SHALL BE FILLED WITH ASTM #8 STONE OR AS RECOMMENDED BY MANUFACTURER.
- C. BEDDING/FILTER LAYER, 2" THICK ASTM #8 STONE OR AS RECOMMENDED BY MANUFACTURER.
- D. RESERVOIR LAYER, ASTM #2 PER PROJECT PLANS. THICKNESS PER PROJECT PLANS (6" MIN.).
- E. SUBBASE LAYER, ASTM #57 STONE. WHEN OMITTED, PROVIDE GEOTEXTILE FILTER FABRIC BELOW RESERVOIR LAYER.
- F. UNCOMPACTED SUBGRADE.
- G. PERVIOUS PORTLAND CEMENT CONCRETE, THICKNESS PER PROJECT PLANS (6" MIN.).
- H. NON-WOVEN GEOTEXTILE FABRIC ALONG SIDE OF STONE LAYERS WHERE NO OTHER EDGE RESTRAINT PROVIDED.
- I. COMPACTED SUBGRADE



REVISIONS

COUNTY OF BERNALILLO

PERMEABLE PAVEMENT

GSI-09

JULY 2022

# TREATMENT TRAIN EXAMPLE

Example of a GSI/LID BMP Treatment Train with Permeable Pavement, Curb Opening with Sediment Trap, Stormwater Bumpout, and Infiltration Trench



# TREATMENT TRAIN EXAMPLE

Example of a GSI/LID BMP Treatment Train with Bioswale, Check Dam, and Stormwater Harvesting Basin

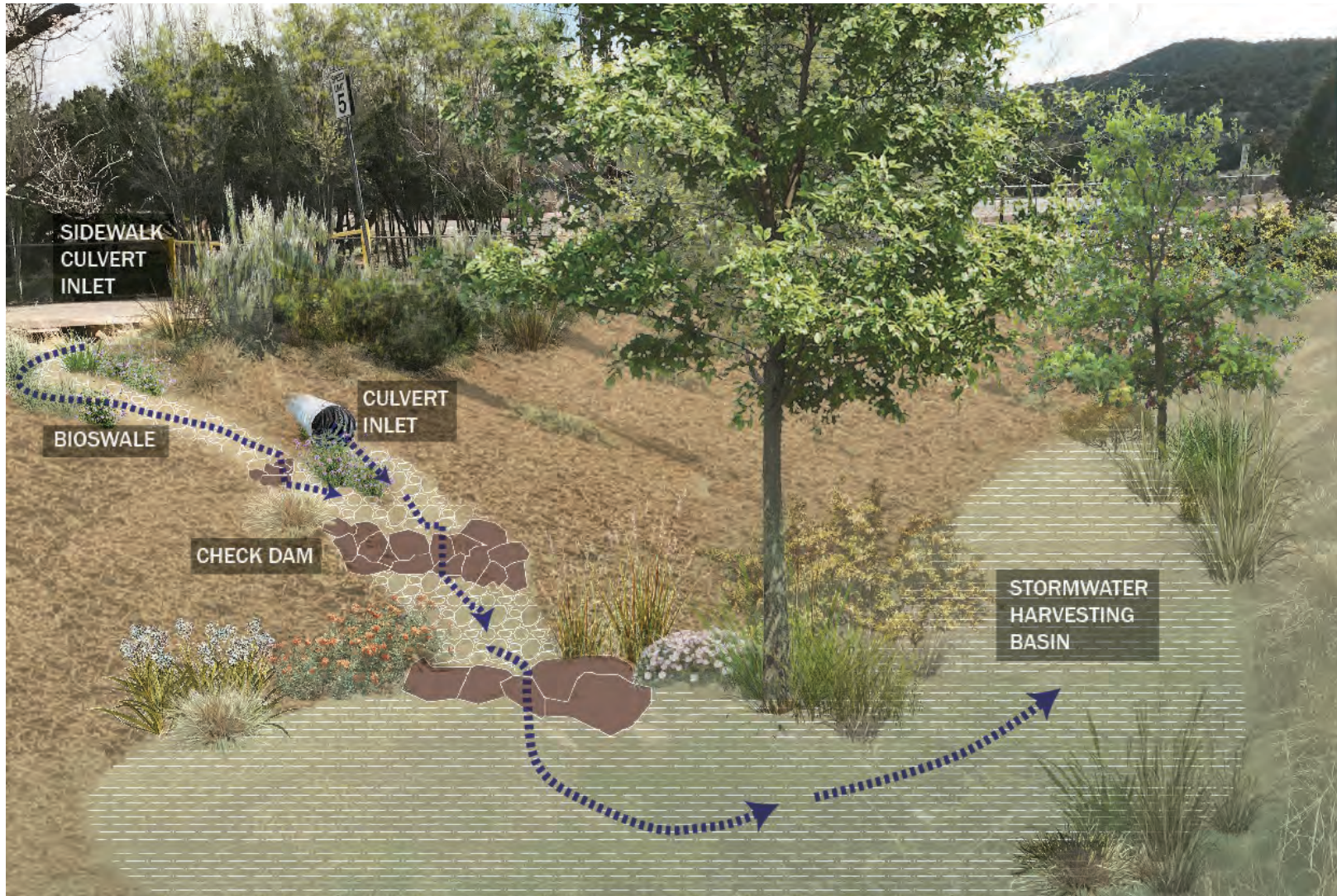

## 6 | GSI/LID BMP Design and Construction

---

Though the appropriate GSI/LID BMPs may vary based on location, common design considerations and construction practices apply whenever GSI/LID BMPs are implemented. This section outlines various considerations developers and project designers should consider prior to design, project approval, and construction.

### *County Review Process*

Private developers and project designers are encouraged to meet with Bernalillo County staff as part of a **pre-application meeting** early in the site development process regarding the incorporation of GSI/LID BMPs into their projects. The applicant should contact the Planning staff at Planning and Development Services to request the pre-application meeting. Planning staff will set up the meeting with applicable staff from the following: Bernalillo County Planning, Zoning, Building, Public Works Development Review, Transportation, and Natural Resources, as well as the Water Authority.

Bernalillo County requires that stormwater quality controls be incorporated into the **grading and drainage plan**. Applicants should maintain communication with Bernalillo County staff throughout the design process to ensure that stormwater quality goals are met in the final design. Early consideration of GSI/LID BMPs can also provide savings and benefits for developers and project designers, as it can be more complicated and expensive to integrate GSI/LID BMPs after the grading and drainage plan and the landscaping plan have been submitted for County review.

Frequent communication within the project team (i.e., project owner(s), engineers, landscape designers/architects, general contractors, landscape maintenance practitioners, etc.) from the beginning of the project through design and construction, is an integral component in the development process and can ensure successful and cost-efficient outcomes for the project.

## Steps in the Bernalillo County Review Process Associated with GSI/LID

1. Hold pre-application meeting (recommended).
2. Submit grading and drainage plan and *Stormwater Post-Construction Green Stormwater Infrastructure/Low Impact Development Best Management Practices Evaluation Form*.
3. County Natural Resource Services and Development Review staff review proposed GSI/LID and stormwater quality BMPs.
4. Receive recommendations/revisions from existing plans; hold optional meetings with County staff.
5. Receive approval of grading and drainage plan.
6. Submit building permit application inclusive of landscape plan.
7. County Natural Resource Services staff review proposed landscaping to ensure it aligns with approved grading and drainage plan, Stormwater Quality and Water Conservation Ordinances, and GSI/LID Standards.
8. Receive recommendations/revisions from existing plan.
9. Receive approval of landscape plan.
10. Receive building permit after plans are approved by all County departments.
11. Construct project.
12. All County departments conduct project inspections. County Natural Resource Services and Development Review staff inspect GSI/LID and stormwater quality BMPs.
13. Submit notarized Covenant for Drainage and Water Quality Infrastructure to Public Works.
14. Receive Certificate of Occupancy.
15. Engineer / Landscape Architect informs facility owner of responsibility for ensuring stormwater quality BMPs are maintained. BMPs must be inspected by a professional engineer or qualified stormwater person every three years, and documentation of maintenance activities and inspections must be provided to the County upon request.



### *General Design Principles*

The following general principles should be applied in the design of GSI/LID BMPs:

- Design GSI/LID conveyances to slow down runoff, to promote infiltration, and to provide filtration to remove pollutants. Meandering designs, that lengthen the flow paths, are encouraged.
- Reduce impervious surfaces to the greatest extent practicable. Impervious surfaces collect and retain pollutants, such as oil and grease, and increase the urban heat island effect.
- Consider access for maintenance during design. Communicate with maintenance personnel during the design process to ensure maintenance requirements are met.
- When sediment and debris accumulation is anticipated in the GSI/LID BMP, incorporate an upstream sediment trap, trash/debris screen, and/or planning for additional required maintenance.
- Design appropriately sized erosion protection, especially at concentrated flow locations.
- Design GSI/LID BMPs to ensure infiltration by avoiding soil compaction of pervious areas and around vegetation, by performing on-site infiltration rate tests, and by using soil amendments, if needed, to improve infiltration.
- Conduct infiltration testing at the proposed bottom elevations of the BMP. In general, infiltration rates greater than 0.5 inches/hour are recommended for BMPs. An underdrain may be needed if the infiltration rate is less than 0.5 inches/hour.
- Consider the depth to the groundwater table and bedrock below each BMP; an underdrain may be needed if the groundwater table and/or bedrock are shallow and will impact infiltration within the BMP.
- Consider the location of existing utilities.
- Avoid inlets or outlets to GSI/LID BMPs flowing directly through ADA compliant ramps or parking spaces.
- Maintain appropriate setbacks from adjacent pedestrian routes and parking spaces where vehicle doors open adjacent to GSI/LID BMPs.
- Follow setback requirements from property lines, as indicated in the County zoning code.
- Coordinate with the project design team and utility owners on required setbacks from buildings/foundations, septic tanks, utility lines, etc.
- Consult the AASHTO Roadside Design Guide when placing and designing BMPs immediately adjacent to travel ways.

### *Maintenance Requirements and Responsibilities*

It is important to consider and define irrigation and maintenance requirements prior to the design of GSI/LID BMPs, as these requirements differ from typical landscaping. The pre-application meeting is an opportunity for developers and project designers to meet with Bernalillo County staff to learn about maintenance requirements associated with different BMPs. Additional information on maintenance can be found in **Section 7: GSI/LID BMP Inspection and Maintenance**.

## *BMP Overflow Control Design Requirements*

GSI/LID BMPs should be designed to accommodate larger, higher-intensity storm events that exceed their storage capacity. The following should be incorporated into BMP overflow design:

- Design the overflow structure with capacity for the 100-year peak outflow rate.
- Consider erosion protection for the overflow structure/emergency spillway during design; it must be sufficient for the flow velocity and flow expansion downstream of the overflow structure.
- Design overflow structures to safely convey flows to downstream drainage facilities or other County approved discharge locations.

## *Plant Selection Considerations*

Project designers should consider the plant selection and location during the design process, as plants are a key element to successful GSI/LID applications. Regionally adapted plants should be selected based on temperature tolerance, soil types, and water needs. Arid region applications that incorporate vegetation as part of the BMP may require supplemental irrigation to support the vegetation during its establishment period. See **Section 9** for guidance on plant selection.

## *Soil Protection During Construction*

It is important to maintain soil permeability and to limit compaction during construction. Best practices to protect soil conditions during construction include:

- Protect the GSI/LID BMP installation area, landscaped areas, and remaining undeveloped areas from

construction equipment that could compact soils and could reduce soil permeability.

- Reserve existing topsoil and reuse it to maintain a healthy growth medium for plant establishment.
- Remove excess sediment that results from construction activities. Accumulated sediment limits infiltration and is a primary reason GSI/LID BMPs fail to operate as designed.
- Scarify soils after construction (recommended) to reduce compaction and to promote infiltration.
- Complete impervious area construction and stabilize pervious areas before runoff is allowed to enter an infiltration BMP.





## *Standard Drawings*





The County review process includes comparison of proposed designs against the Standard Drawings in this GSI/LID Standards document to ensure that the designs are buildable and are appropriately selected and located. Table 3 lists the typical design data the County requires on project plans for each GSI/LID BMP included and described in this document. See **Section 5** for Standard Drawings for each BMP recommended by Bernalillo County.

## *County Construction Inspections*

All County departments inspect construction projects. County Natural Resource Services and Development Review staff inspect GSI/LID BMPs and stormwater quality controls after construction and prior to the applicant receiving a Certificate of Occupancy.

Table 3: Typical Design Data Required for GSI/LID BMPs

BMP	Standard Drawing Number	GSI/LID Standard Drawing	Typical GSI/LID BMP Design Data Required on Project Plans
 <p>CURB OPENING</p>	GSI-01	Curb Opening	<ul style="list-style-type: none"> <li>• Curb opening length (L) – recommend 2-ft. minimum.</li> <li>• Identify if sediment trap is required.</li> <li>• Sediment trap dimensions, if required.</li> <li>• Riprap rundown/erosion protection dimensions, stone size, and riprap thickness.</li> <li>• Elevation of flowline at curb opening and elevation at bottom of sediment trap or adjacent BMP.</li> <li>• Gutter transition, if different from County Standard Drawing 2207.</li> </ul>
 <p>STORMWATER BASIN</p>	GSI-02	Stormwater Harvesting Basin	<ul style="list-style-type: none"> <li>• Erosion protection type and dimensions; if riprap, provide stone size and riprap thickness.</li> <li>• Ponding depth for SWQV – recommend 9-in. maximum.</li> <li>• Water surface elevation at 100-year overflow depth.</li> <li>• Freeboard measurement – recommend 3-in. minimum.</li> <li>• Mulch type, thickness, and location.</li> </ul>
 <p>STORMWATER BUMPOUT</p>	GSI-03	Stormwater Bumpout	<ul style="list-style-type: none"> <li>• Bump out radius – recommend 10-ft. minimum.</li> <li>• Bumpout dimensions.</li> <li>• Riprap/erosion protection dimensions, stone size, and riprap thickness.</li> <li>• Design storm velocity.</li> <li>• Ponding depth for SWQV – recommend 9-in. maximum.</li> <li>• Mulch type, thickness, and location.</li> </ul>
 <p>BIOSWALE</p>	GSI-04	Bioswale	<ul style="list-style-type: none"> <li>• Design storm velocity; if velocity is greater than 3 fps, check dam(s) required.</li> <li>• Freeboard measurement – recommend 3-in. minimum.</li> <li>• Erosion protection type and dimensions; if riprap, provide stone size and riprap thickness.</li> <li>• Mulch type, thickness, and location.</li> </ul>

BMP	Standard Drawing Number	GSI/LID Standard Drawing	Typical GSI/LID BMP Design Data Required on Project Plans
 <p>DEPRESSED MEDIAN</p>	GSI-05	Depressed Median	<ul style="list-style-type: none"> <li>• Design storm velocity – if velocity greater than 3 fps, check dam(s) required.</li> <li>• Freeboard measurement – recommend 3-in. minimum.</li> <li>• Erosion protection type and dimensions; if riprap, provide stone size and riprap thickness.</li> <li>• Mulch type, thickness, and location.</li> </ul>
 <p>INFILTRATION TRENCH</p>	GSI-06	Infiltration Trench	<ul style="list-style-type: none"> <li>• Filter layer and reservoir layer dimensions.</li> <li>• Filter layer and reservoir layer stone size. Specify aggregate size per ASTM D-448 – Standard Classification for Sizes of Aggregate for Road and Bridge Construction.</li> <li>• Erosion protection type and dimensions; if riprap, provide stone size and riprap thickness.</li> <li>• Mulch type, thickness, and location.</li> </ul>
 <p>CHECK DAM</p>	GSI-07	Check Dam	<ul style="list-style-type: none"> <li>• Check dam height.</li> <li>• Check dam shelf width.</li> <li>• Depth embedded below grade – recommend 6-in. minimum.</li> <li>• Elevations for top of check dam weir.</li> <li>• Elevation at top of bioswale/channel/ditch at check dam location.</li> <li>• Aggregate type and size or specification (sized for design storm flow conditions).</li> <li>• Freeboard measurement – recommend 3-in. minimum.</li> </ul>
 <p>OUTLET CONTROL STRUCTURE</p>	GSI-08	Outlet Control Structure	<ul style="list-style-type: none"> <li>• Concrete drop inlet type and size.</li> <li>• Outlet control plate dimensions.</li> <li>• Elevations for inlet grate and inlet sump.</li> <li>• Storm drain outfall size and invert elevation.</li> </ul>
 <p>PERMEABLE PAVEMENT</p>	GSI-09	Permeable Pavement	<ul style="list-style-type: none"> <li>• Pavement type and thickness.</li> <li>• Bedding/filter layer thickness, if applicable.</li> <li>• Reservoir layer thickness – recommend 6-in. minimum.</li> <li>• Subbase layer thickness, if applicable.</li> <li>• Stone size for all layers. Specify aggregate size per ASTM D-448 – Standard Classification for Sizes of Aggregate for Road and Bridge Construction.</li> </ul>

## 7 | GSI/LID BMP Inspection and Maintenance

### *Inspection and Maintenance Responsibilities*

Inspection and maintenance for GSI/LID on **private property** is the responsibility of the facility/property/landowner. As required by Bernalillo County's Stormwater Quality Ordinance, periodic inspection and certification of private BMP facilities by a state licensed professional engineer or by an otherwise qualified stormwater person (as determined by the county engineer) are required of the facility/property/landowner and shall occur not less than once every three years from the date of final construction inspection. Additional information on the Post-Construction Inspection Program requirements can be found at [www.bernco.gov/gsi-lid](http://www.bernco.gov/gsi-lid).

Inspection and maintenance for GSI/LID along **roadways and in the public right-of-way** that are installed by a developer as part of a site improvement project are generally the responsibility of Bernalillo County, unless agreements are in place with a homeowners association or other entity. When GSI/LID BMPs are located in the public right-of-way, the Bernalillo County review process will determine whether the proposed applications are consistent with the County's maintenance practices.

### Maintenance Approach for GSI/LID BMPs

For green stormwater infrastructure to function properly and allow water to soak into the ground over time, maintenance is needed. Routine maintenance on vegetated green stormwater infrastructure is similar to general landscape maintenance: removing invasive species, picking up trash and debris, and keeping plants healthy. In addition, GSI/LID BMPs also require periodic removal of accumulated sediments and adhered pollutants.

Some maintenance benefits of GSI/LID BMPs over traditional landscape installations include:

- Native and arid-adapted plants use less fertilizers, herbicides, and pesticides.
- Native and arid-adapted plants use less water.
- Native and arid-adapted plants have increased survivability rates and tend to be more resistant to disease and drought. Increased survivability rates decrease the time and resources needed for replacing plants.

Source: Arid LID Coalition, *Middle Rio Grande Green Stormwater Infrastructure Maintenance Manual*, 2022.

### *Inspection and Maintenance Best Practices*

The following are best practices to ensure proper maintenance of GSI/LID BMPs:

- Conduct inspections of GSI/LID BMPs at a recommended minimum of once per year or more, as well as after storms greater than 0.25 inches.
- Remove debris, trash, and accumulated sediment regularly from pretreatment structures and GSI/LID BMPs. Accumulated sediment limits infiltration and is a primary reason GSI/LID BMPs fail to operate as designed. The accumulated sediment should be removed if it reduces the BMP capacity or if it impacts the inflow or outlet locations.
- Inspect and repair erosion issues. Areas subject to erosion include side slopes, riprap rundowns, concentrated flow locations, areas of high velocity flow, or areas where human traffic may disturb the vegetation.
- Some GSI/LID BMPs may require use of specialized equipment for maintenance, such as permeable pavement and outlet control structures. See the technical guidance sheets for maintenance guidance.
- Prune and replace plants as needed. Remove invasive plant species.
- Irrigate regularly during the plant establishment period (see **Section 9** for establishment period guidance). Once plants are established, irrigate only as necessary.
- Leave organic debris in place whenever feasible to biodegrade. This practice promotes healthy soils.
- If a neat or uniform appearance is desired, the surface can be lightly raked or a 1-inch layer of replacement

organic mulch can be applied. See **Section 8** for additional guidance on the use of mulch.

- BMPs that are seeded and that feature grass cover typically should not be mowed more than once a year.

### *Other Maintenance Considerations*

Signs may be posted within or adjacent to the BMP to clarify maintenance requirements and to ensure that no equipment is used that might compact the soils within the BMP.

The owner of the BMP may also consider including educational information regarding the function and benefits of GSI/LID for the general public. GSI/LID native plantings often generate calls from the public concerned about the perceived lack of maintenance; educational information signs may be appropriate to educate the public about GSI/LID features.

## 8 | Mulch in GSI/LID BMPs

### *Benefits and Preferred Materials*

Mulch serves to stabilize the surface and to reduce evaporation from the soil. It is also a critical component of GSI/LID installations. **Organic mulch**, which contributes to pollutant treatment and to containment through filtration and development of a healthy soil microbiome, should be used wherever possible. By contrast, rock and inorganic mulch materials, such as gravel, gravel mulch, pebbles, lava rock, or crushed rock, contribute less to the treatment of runoff and less to the biological health of soil and plants. They also store and release heat. In addition, staining from runoff is not as apparent on organic mulch as it is on rock and inorganic mulch.

#### Key Definition: Soil Microbiome

The soil microbiome is the dynamic community of microorganisms associated with plants and soil. This community includes bacteria, archaea, and fungi. The composition of any particular microbiome is influenced by myriad factors, including environmental, soil physical properties, nutrient availability, and plant species.

**Preferred mulch materials** are shredded, partially composted wood mulch, installed at a 3-inch depth. Shredded wood mulch locks together, making it more resistant to floating or to blowing away.

Partially composted mulch contains healthy bacteria and fungi that contribute to soil health. Runoff from storms will

activate soil fungi, causing it to “glue” the soil to the mulch, making it non-floatable under moderate slope conditions.

### *Best Practices in the Use of Mulch*

Below are best practices to follow when using mulch with GSI/LID BMPs:

- Organic mulch 3-inch deep should last at least three years; mulch may be top-dressed annually to freshen its appearance. If the BMP receives frequent or high-volume flows, mulch may need to be refreshed more frequently.
- Leaf litter does not need to be removed from the surface of areas with organic mulch.
- Avoid organic mulch products containing bark chips or products likely to blow away.
- Keep all mulch at least 4 inches away from the base of new trees and plants.
- If seeding an area, hydromulch or a thin layer of small rock mulch (less than 1.5 inches deep) is recommended over drill seeding or hand broadcast seeding. Follow Section 632 of the [NMDOT Standard Specifications for Highway and Bridge Construction](#).

### *Use of Rock and Inorganic Mulch*

Inorganic mulch is not preferred, although, it may be appropriate in some contexts. If inorganic mulch is necessary, install a 3-inch depth of organic chipped wood mulch below the inorganic mulch wherever possible or install weedblock fabric. Other considerations include:

- Use rock and inorganic mulch materials where velocity exceeds 1 foot-per-second (fps). Inorganic mulch requirements (e.g., rock size and thickness) shall be

informed by evaluation of hydraulic conditions for the GSI/LID BMP.

- Chipped, non-composted wood mulch is recommended to be used under rocks and under inorganic mulch materials, as it degrades more slowly than shredded, partially composted wood mulch.
- If using rock or inorganic mulch, double-washing the materials to sufficiently remove dust and other coatings is recommended. Rock and inorganic mulch contains fine grains which can create additional sediment accumulation around infiltration BMPs, clogging soils and decreasing infiltration.
- If rock and inorganic mulch is used, plan for maintenance to remove sediment and debris from the mulch; weeds will grow in sediment that accumulates in the rock and inorganic mulch.
- Dark-colored rock and inorganic mulch materials, such as basalt, are preferred for areas that will be stained by urban runoff. Light-colored rock and inorganic mulch materials are preferred for other areas, because it attracts less heat than dark colored materials.

*Figure 7: Preferred Mulch Type: Shredded, Partially Composted Wood Mulch*



*Photo source: Soilutions*

### *Use of Weedblock*

Use of weedblock (geotextile) fabric for weed control is not a preferred practice in GSI/LID features because it separates the stormwater runoff from the soil and plant roots which need direct contact with mulch for pollutant treatment. Most weedblock fabrics are only permeable when fully saturated; as such, runoff from small storm events may not reach plant roots and soil microbes. In addition, weedblock fabric can become ineffective when sediment accumulates on top of the fabric, allowing weeds to grow. Weedblock fabric is not necessary under a 3-inch depth or greater of organic mulch. Rather than using weedblock, appropriately applied shredded wood mulch is effective for preventing weed growth, while also effective for supporting healthy soils and plants.



Figure 8: Mulch Selection for GSI/LID BMPs

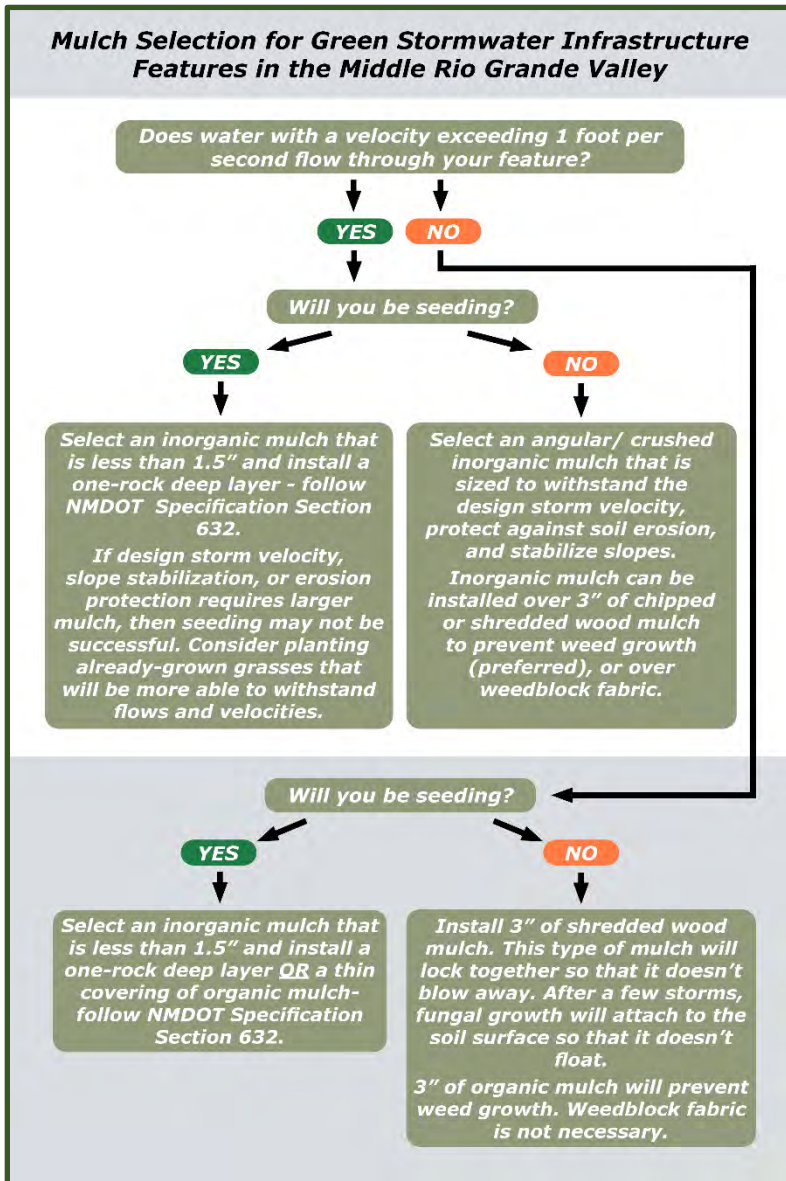

## 9 | GSI/LID Plant Selection

### General Considerations

Plants in GSI/LID features are an important part of an engineered system. Soil pore space and organic material created by plant roots maintain and improve infiltration rates for stormwater. Plant roots stabilize soil and reduce erosion. Plants provide shade and habitat, while making the GSI/LID feature more attractive and regionally unique. This increases public acceptance. The Appendix provides a list of plants appropriate for use in and around GSI/LID BMPs in the Middle Rio Grande Valley.

GSI/LID BMPs should include at least three species within each plant type (i.e., tree, shrub, perennial, grass) to ensure that some species will live in the event of extreme drought or insect infestation. Species diversity is also critical for wildlife habitat.

#### Steps in Plant Selection Process

1. Identify ecological biome
2. Determine elevation zone
3. Identify planting location in GSI/LID BMP (inundation zone, transition zone, or high ground zone)

Plants must be appropriately selected and be maintained for the GSI/LID BMP to function properly. To aide in plant selection, the plant list is organized by ecological biome, elevation zone, planting locations (or infiltration zones), and plant type (trees, shrubs, perennials, and grasses). The Plant

List Components and Selection section below provides steps on using the plant list during GSI/LID BMP design.

Figure 9 provides a flow chart outlining how to use the plant selection criteria in the plant list in the Appendix to identify appropriate plants for the GSI/LID BMP.

#### Criteria for Plant List

- Can survive without irrigation after establishment in a GSI/LID BMP
- Has the ability to stabilize soil
- Is heat, drought, and cold tolerant
- Is non-invasive
- Is appropriate for GSI/LID infiltration zones

### Plant List Components and Selection

#### Ecological Biome

The **first step** in using the plant list is to determine the ecological biome location of the GSI/LID BMP. See Figure 9 and Table 4 to determine the ecological biome for the project.

Across all elevation zones, four general biome categories are recognized for simplified plant selection: two are urban and two are non-urban. Within *urban areas*, the two biomes are **Urban Ephemeral Riparian**, which is the biome in and around unpaved arroyos, and **Urban Desert Grassland/Shrubland**. In *non-urban areas*, the two primary biomes are **Riparian** and **Shrub Desert Grassland**. Riparian biomes occur along acequias, ditches, the Rio Grande, and Tijeras Creek, while other areas can generally be classified as Shrub Desert Grassland. Non-urban locations include the East

Mountains, North Albuquerque Acres, the North and South Valleys, and other areas of unincorporated Bernalillo County.

**Table 4: Ecological Biomes in the Middle Rio Grande Watershed**

Biome	Urban	Non-Urban	Stream or Arroyo
Urban Ephemeral Riparian	✓		✓
Urban Desert Grassland/Shrubland	✓		
Shrub Desert Grassland		✓	
Riparian		✓	✓

**Figure 9: Ecological Biome Selection Flow Chart**

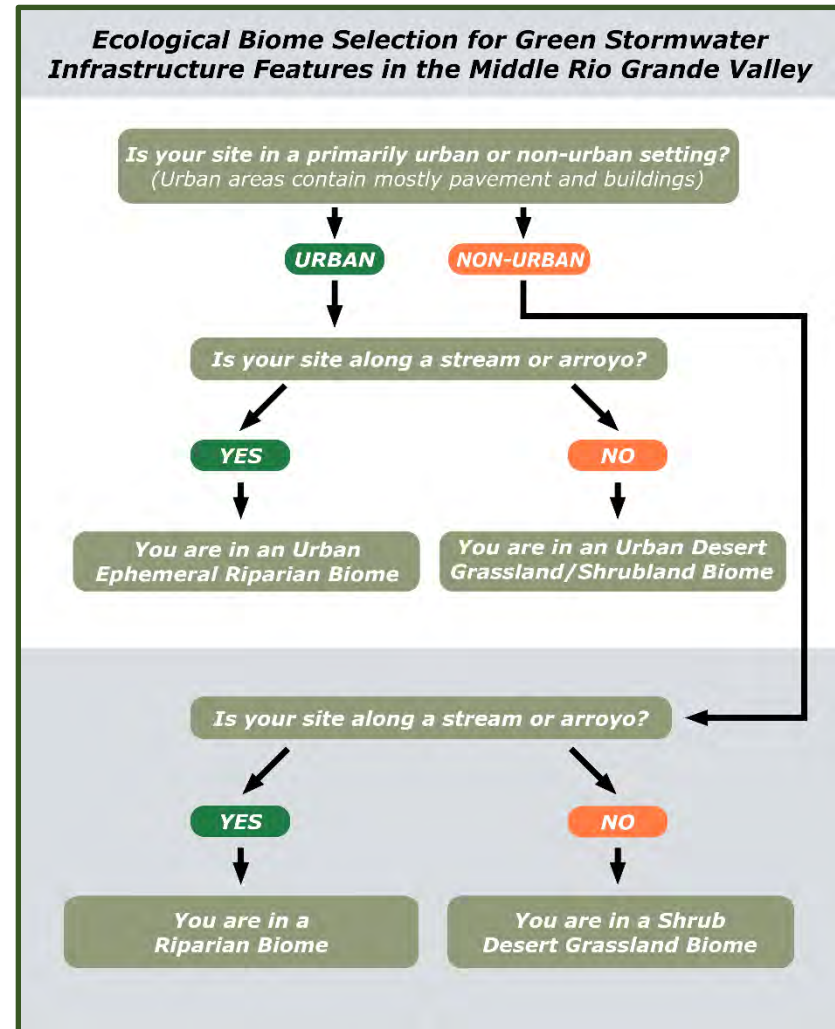

**Elevation Zone**

The **second step** in using the plant list involves identifying the elevation zone, which can be determined by locating the project area within one of the five zones depicted in Figure 10 and Figure 11.

Elevation, soil types, and annual precipitation amounts vary within the Middle Rio Grande watershed. This affects plant species selection. There are five elevation zones, or areas of similar elevation and climate, across the Middle Rio Grande watershed:

1. West Mesa (west of Coors Blvd.)
2. Valley (between Coors Blvd. and Edith Blvd.)
3. East Mesa (from Edith Blvd. to Juan Tabo Blvd.)
4. Foothills (Juan Tabo Blvd. to the National Forest)
5. East Mountains (along NM 14 and NM 337)

**Figure 10: Elevation Zones across Bernalillo County**

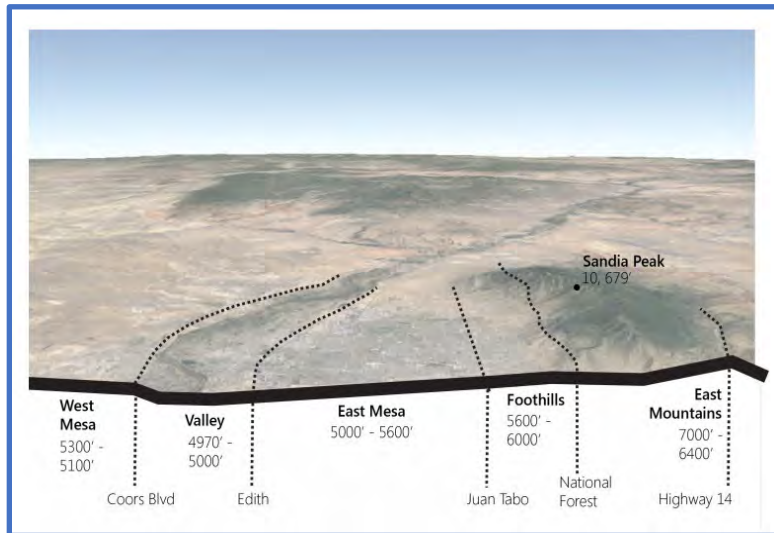

**Figure 11: Geographic Area for Elevation Zones**

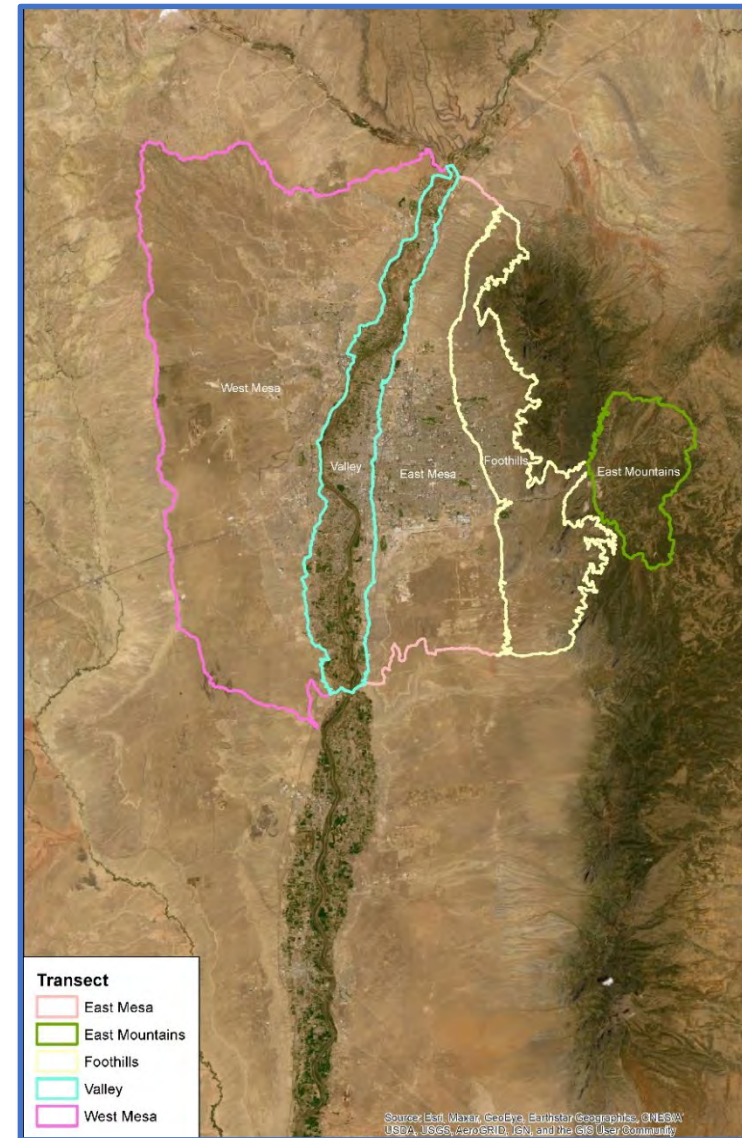

### Planting Locations (or Infiltration Zones)

The **third step** for using the plant list is determining the planting location within the BMP. Plant selection must be appropriate for the varying moisture conditions in the GSI/LID feature. The planting locations for a GSI/LID BMP include the inundation zone at the bottom of the basin or swale, the transition area along the side slopes, and high ground at the top of the GSI/LID BMP (see Figure 12).

*Figure 12: Planting Locations within GSI/LID BMPs*

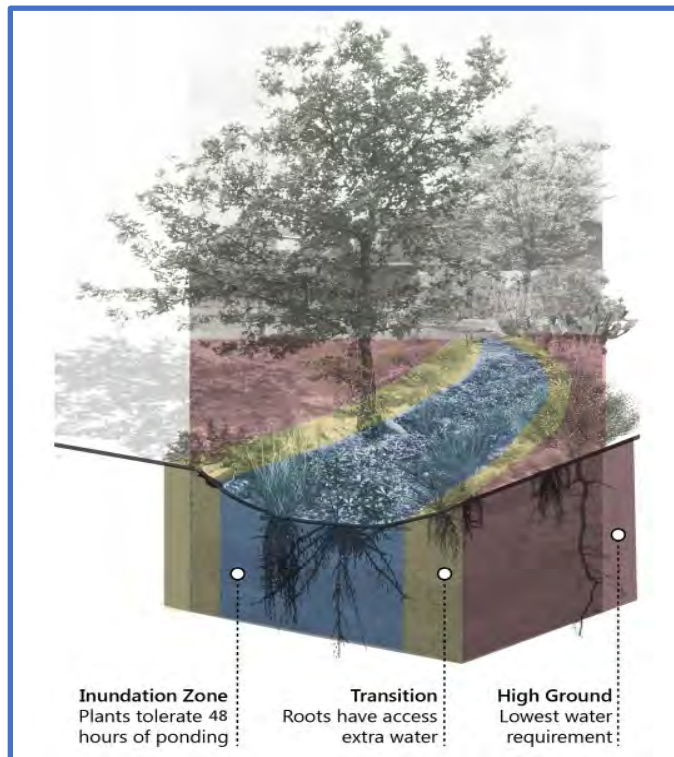

### Inundation Zone

The inundation zone is located at the base of a GSI/LID BMP and is where water pools in heavier rainfall events. The depth of the inundation zone will be determined by the unique hydraulics of the GSI/LID BMP. The capacity, drainage outfall, and permeability of the soils will all impact how deep the water ponds within and how quickly it drains from a BMP. Most drought-adapted plants require good drainage, including those that can tolerate temporary inundation. If an infiltration BMP does not drain within 48 hours, even inundation-tolerant plants may not survive.

### Transition Zone

The transition zone is typically located on the side slopes of the GSI/LID BMP, above the inundation zone and below the top of the slope for the BMP. It refers to the non-saturated area where capillary rise moves water upwards through the soil from the inundation zone.

### High Ground Zone

The high ground zone typically is located above and surrounds the transition zone and is sloped as needed to tie the GSI/LID BMP to the surrounding landscape. This area is not typically inundated and can support a variety of upland and drought-tolerant plants.

### Plant Species Diversity

GSI/LID features should include at least three species within each plant type (i.e., tree, shrub, perennial, grass) to ensure that some species will live in the event of extreme drought or insect infestation. Species diversity is also critical for wildlife habitat.

*Runoff Requirements for Trees*

Each tree on the plant list should receive runoff from at least 1,500-3,500 sq. ft. of impervious surface (e.g., concrete or asphalt) to survive without irrigation after establishment. Lower water use trees, such as desert willow and mesquite, require closer to 1,500 sq. ft., while higher water use trees, such as cottonwood and Arizona sycamore, require upwards of 3,500 sq. ft.

*Planting Recommendations*

The following procedures should be followed to promote plant growth with GSI/LID BMPs:

- Protect soil from compaction or scarify soil before planting.
- Nursery-grown plants should be planted in the fall (i.e., October and November) to promote root establishment and to minimize irrigation needs. Fall planting of nursery-grown plants is preferred, as it gives them five to six months for root growth before they are stressed by warm temperatures and winds.
- In general, seeds should be planted in early fall, because the soil is still warm, soil moisture is present, and intense storms that wash away seeds are less likely. Seeding guidance can be found in Section 632 of the [NMDOT Standard Specifications for Highway and Bridge Construction](#) for weather limitations for seeding.

*Establishment Periods*

To achieve water conservation benefit from GSI/LID, plants in GSI/LID features should be drought-adapted and generally able to survive without irrigation, once established. Depending on species selection and site factors, continued irrigation may be needed for trees. Although in some conditions, tree species may not need irrigation beyond establishment, some trees merit continued, efficient irrigation due to the multitude of benefits they provide to the community. The irrigation system placement will likely change as the landscape matures. Supplemental irrigation for all plant types may also be required during periods of prolonged drought. Table 5 outlines establishment periods by plant category under normal precipitation conditions. Table 6 provides guidelines for plant establishment for GSI/LID features.

**Table 5: Arid Environment Establishment Periods**

<b>Plant Type</b>	<b>Establishment Period</b>
<b>Trees</b>	10-15 years
<b>Shrubs</b>	3-5 years
<b>Perennials/grasses</b>	1-2 years

**Table 6: Establishing Guidelines for GSI/LID Features**

<b>Are you planting trees?</b>
<b>Yes</b>
<p>You will need to irrigate for 10 to 15 years to establish a healthy tree. This range depends on available precipitation, selected species, soil health, reflected heat, and time of planting. This range assumes each tree receives runoff from between 1,500 to 3,500 sq. ft. of impervious surface.</p> <p>A durable irrigation system is recommended, such as PVC pipe and bubblers or netafim. Drip systems generally do not last more than 8 years.</p> <p>If you are also planting shrubs/smaller plants in addition to the tree(s), consider putting them on a separate irrigation zone so the shrub zone can be turned off while the tree zone continues to be on. It is also possible to cap bubblers for shrubs after they are established (3-5 years), while leaving on bubblers for trees for at least 10-15 years.</p>
<b>No</b>
<p>Shrubs require at least 3-5 years of irrigation for establishment. This range depends on available precipitation, selected species, soil health, reflected heat, and time of planting.</p> <p>A drip system may be sufficient to meet established irrigation needs for shrub perennials, although it will require consistent maintenance to ensure functionality for 3-5 years.</p> <p>If you are seeding, installing a temporary spray irrigation system will greatly improve results. Depending on available precipitation, spray irrigation may only be needed for 1 year.</p> <p>Wildflowers and grasses respond to precipitation but may go dormant without soil moisture. If continuous growth/blooms are desired, irrigation will be necessary.</p>

## Glossary

---

**Best Management Practices (BMPs):** Set of methods that detain, disperse, attenuate, infiltrate, and/or filter stormwater runoff from impervious surfaces such as streets, sidewalks, rooftops, and parking areas. These practices are designed to manage stormwater runoff and to improve water quality by preventing or by reducing pollutants in stormwater runoff.

**Bioswale:** A shallow, linear, or curvilinear feature designed to improve water quality by conveying, slowing, and treating runoff; allows pollutants to settle out and promotes infiltration.

**BMP Standard Drawings:** Detailed guidance on the design and construction of BMPs.

**BMP Technical Guidance Sheets:** Definitions, general design, and maintenance guidance, as well as appropriate application locations.

**Check Dam:** A shallow, typically permeable control placed perpendicular to the flow of water within a drainage feature that slows the flow, increasing infiltration as well as retaining sediment and debris.

**Curb Opening:** An opening in a curb to allow stormwater from an impervious surface, such as roads, parking lots, or hardscape areas, to flow into an infiltration area. Typical design includes a sediment trap located behind the curb opening.

**Depressed Median:** A linear or curvilinear shallow depression located in the roadway median designed to improve water quality by conveying, slowing, and treating runoff; allows pollutants to settle out and promotes infiltration.

**Green Stormwater Infrastructure (GSI):** A method of sustainable stormwater management that focuses on treating stormwater runoff prior to it entering rivers, streams, aquifers, and other waterways by leveraging the ecological functions of living, natural systems.

**High Ground Zone:** The planting location (or infiltration zone) area that is typically located above and surrounds the transition zone and is sloped as needed to tie the GSI/LID BMP to the surrounding landscape. This area is not typically inundated and can support a variety of upland and drought-tolerant plants.

**Hydromulch:** A thin layer of small rock mulch (less than 1.5 inches deep) which can reduce erosion and provide protection for grass seed.

**Infiltration Trench:** A linear excavated area that is lined with filter fabric and filled with rock in order to create additional space for runoff to collect and infiltrate into adjacent permeable soils.

**Inundation Zone:** The planting location (or infiltration zone) area that is located at the base of a GSI/LID BMP and is where water pools in heavier rainfall events.



**Land Treatment C:** Follows the definition from the City of Albuquerque Development Process Manual (DPM) with minor modifications: Soil compacted by human activity with minimal vegetation, including unpaved parking, roads, and trails. Irrigated lawns and parks with slopes greater than 10 percent. Native grasses, weeds, and shrub areas, and soil uncompacted by human activity with slopes at 20 percent or greater. Native grasses, weeds, and shrub areas with clay or clay loam soils and other soils of very low permeability, as classified by SCS Hydrologic Soil Group D.

**Land Treatment D:** Follows the definition from the City of Albuquerque Development Process Manual (DPM): Impervious areas such as pavement and roofs. This area includes ponds, channels, and wetlands, even if these areas are seasonally dry.

**Low Impact Development (LID):** Design and development practices that work with nature to reduce the stormwater runoff volume generated and to minimize or to eliminate adverse impacts to stormwater quality.

**New Development:** In relation to the retention of the stormwater quality design volume, is defined as a project that is developed on a site with little or no existing impervious cover. This can include an undeveloped property or a property that had previously been developed, but site improvements and impervious cover have been mostly or completely removed so that site constraint issues related to existing infrastructure no longer exist.

**NPDES MS4 Permit:** The National Pollution Discharge Elimination System (NPDES) Municipal Separate Storm Sewer System (MS4) Permit is issued by the EPA and requires permittees to develop and implement a comprehensive Storm Water Management Program to control the quality of storm water discharged into waters of the United States.

**Organic Mulch:** A type of mulch derived from material that was once living. The preferred mulch type for GSI/LID BMPs is shredded, partially composted wood mulch, installed at 3-inch depth, minimum. Shredded wood mulch locks together, making it more resistant to floating or to blowing away. Partially composted mulch contains healthy bacteria and fungi that contribute to soil health. Runoff from a few storms will activate soil fungi which will “glue” the soil to the mulch, making it non-floatable.

**Outlet Control Structure:** A structure placed at the discharge point from a BMP or detention pond designed to regulate the release of stormwater and to facilitate capture of sediment and floatables.

**Permeable:** Refers to anything permitting fluid to pass through. Synonym for pervious.

**Permeable Pavement:** Paving material that allows stormwater to move through the pavement’s surface to a storage layer below, allowing infiltration into the underlying soil. Includes, but is not limited to, permeable interlocking pavers, asphalt, and concrete.

**Plant List:** Identification of native and drought-tolerant plants appropriate for GSI/LID locations across Bernalillo County.

**Predevelopment Hydrology:** In general, the rainfall volume at which runoff would be produced from an area in its natural condition, prior to development disturbances. For the purposes of stormwater quality, this means managing the stormwater runoff volume generated by a storm event prior to discharge to mimic the release of runoff volumes which would have occurred prior to site disturbance.

**Redevelopment:** In relation to retention of the stormwater quality design volume, is defined as a development project that alters the footprint of an existing site, building, or impervious area. Redevelopment projects have site constraints typically not found in new development projects.

**Regulatory Requirements:** Bernalillo County regulatory environment and review process.

**Riparian:** Defined by its relative location to a watercourse. Riparian biomes occur along acequias, ditches, the Rio Grande, and Tijeras Creek.

**Rural Type Roads:** Roads that do not typically feature curb and gutter. Some GSI/LID BMP techniques, such as bioswales and stormwater harvesting basins, are appropriate for rural type roads.

**Shrub Desert Grassland:** Transitional vegetation type that separates the deserts of lowlands from the higher elevation shrublands and woodlands.

**Soil Microbiome:** The dynamic community of microorganisms associated with plants and soil. This community includes bacteria, archaea, and fungi. The composition of any particular microbiome is influenced by myriad factors, including environmental, soil physical properties, nutrient availability, and plant species.

**Stormwater Bumpout:** An area for infiltration and green infrastructure interventions created when the curb and gutter are moved out into the portion of the roadway normally reserved for parking. Otherwise known as 'bulbouts' or 'chicanes'.

**Stormwater Harvesting Basin:** A stormwater harvesting basin is designed for capture and infiltration of stormwater runoff to support vegetation, to regulate discharge rates, and to improve water quality.

**Stormwater Quality Design Storm/Event:** The 90th percentile storm event for new development and the 80th percentile storm for redevelopment using the methodologies specified in EPA publication number 832-R-14-007, or developed for site-specific application using methodology described therein, or based on a site-specific predevelopment hydrology and associated storm event discharge volume specified therein. *(Note: The storm event, as just defined and taken from the MS4 Permit, is used to determine the rainfall depth above which measurable runoff first occurs under natural conditions.)*

**Stormwater Quality Design Volume:** The discharge volume associated with the stormwater quality design storm/event. The amount of stormwater from any given event that should be captured and treated in order to remove a majority of stormwater pollutants on an average annual basis before it is transported to receiving waters.

**Transition Zone:** The planting location (or infiltration zone) area that is typically located on the side slopes of the GSI/LID BMP, above the inundation zone, and below the top of the slope for the BMP. It refers to the non-saturated area where capillary rise moves water upwards through the soil from the inundation zone.

**Treatment Train Guidance:** Examples of how BMPs can be used in combination (i.e., treatment trains).

**Urban Type Roads:** Roads that typically manage stormwater through curb and gutter and may include medians and landscape buffers. Urban type roads have a variety of opportunities for the application of GSI/LID BMPs.

**Urban Ephemeral Riparian:** The biome in and around unpaved arroyos.

**Urban Grassland/Shrubland:** The biome that encompasses meadows and lawns in domestic gardens, parks, vacant land, remnants of rural (non-urban) landscape, and areas along transportation corridors.

## Appendix: Plant List

---

Bernalillo County’s plant list is located on its website: [www.bernco.gov/plantlist](http://www.bernco.gov/plantlist). The plant list reflects preferred plants by biome and elevation zone and planting location (or infiltration zone) for the following plant types:

- Trees
- Shrubs
- Perennials
- Grasses

Trees

Botanical Name	Common Name	Mature Size (Height x Spread)	Biome				Elevation Zone and Infiltration Zone (I = inundation, T = transition, H= high ground)					Evergreen / Semi-	Notes	
			Urban Ephemeral Riparian	Urban Grassland/ Shrubland	Shrub Desert Grassland	Riparian	West Mesa	Valley	East Mesa	Foothills	E. Mntn			
<b>TREES</b>														
<i>Acacia syn Senegalia greggii</i> *	Catclaw acacia	10' x 15'	X	X	X	X	I, T	I, T	I, T	-	-		Fast grower, good barrier plant, marginally cold hardy	
<i>Celtis laevigata</i> - <i>reticulata</i>	Netleaf hackberry	25' x 25'	X	X	X	X	I, T	I, T	I, T	I, T, H	I, T, H		Small red fruits in fall	
<i>Cercis mexicana</i>	Mexican redbud	20' x 15'	X	X		X	-	I, T	-	-	-		May be difficult to transplant.	
<i>Chilopsis linearis</i>	Desert willow	20' x 25'	X	X	X	X	I, T, H	I, T, H	I, T, H	I, T, H	-		Blooms summer and fall	
<i>Crataegus ambigua</i>	Russian hawthorn	15' x 20'	X				X	-	-	-	-	I	May require supplemental water	
<i>Juniperus chinensis</i> 'Keteleeri'	Keteleeri juniper	15' x 10'	X	X	X			T	T, H	T	T, H	T, H	E	A more heat-tolerant Juniper
<i>Juniperus monosperma</i> *	One-seed juniper	15' x 20'		X	X			T, H	T, H	T, H	T, H	T, H	E	Only plant female of species
<i>Koeleruteria paniculata</i>	Golden rain tree	20' x 20'	X			X	-	I, T	I	I, T	I, T			Attracts box elder bugs
<i>Maclura pomifera</i>	Osage orange	25' x 25'	X	X	X	X	-	I, T	I, T	I, T	I, T			Orange-size green fruits on female trees
<i>Pinus eldarica</i> *	Afghan pine	40' x 20'	X	X	X		T	T	T	T	-	-	E	Protect from inundation
<i>Pinus pinea</i> *	Italian stone pine	60' x 50'	X	X			T	T	T	-	-	-	E	Protect from inundation
<i>Pistacia chinensis</i>	Chinese pistache	40' x 20'	X			X	I	I	I	I, T	I, T			
<i>Platanus mexicana</i>	Mexican sycamore	50' x 30'				X	-	I	-	I	-			Included on this list on a trial basis
<i>Platanus wrightii</i>	Arizona sycamore	60' x 70'				X	-	I	-	I	I			Requires plentiful and consistent runoff
<i>Populus deltoides</i> var. <i>wislizenii</i> *	Rio Grande cottonwood	50' x 60'				X	-	I	-	-	-	I, T		Premier wildlife habitat
<i>Prosopis glandulosa</i>	Honey mesquite	25' x 30'	X	X	X	X	I, T, H	I, T, H	I, T, H	-	-			Yellow flowers in summer
<i>Prosopis pubescens</i>	Screwbean mesquite	20' x 20'	X	X	X	X	I, T, H	I, T, H	I, T, H	-	-			
<i>Quercus arizonica</i>	Arizona white oak	25' x 25'	X			X	-	I, T	I, T	-	-	E		Included on this list on a trial basis
<i>Quercus fusiformis</i>	Escarpment live oak	25' x 30'	X			X	-	I, T	I, T	I, T	-	E		Texas native
<i>Quercus gambelii</i>	Gambel oak	25' x 25'	X			X	-	I, T	-	I, T	I, T, H			Requires supplemental water during drought
<i>Quercus muhlenbergii</i>	Chinquapin oak	40' x 50'	X			X	-	I, T	-	I, T	I, T			Texas native
<i>Quercus turbinella</i>	Scrub live oak	18' x 20'	X			X	-	I, T	I, T	I, T	I, T	E		Native in Sandia Mountains
<i>Rhus lanceolata</i> *	Prairie flameleaf sumac	15' x 20'	X			X	-	I, T	I	I, T	I, T			Fast growing, can form thickets
<i>Robinia neomexicana</i> *	New Mexico locust	25' x 15'	X	X	X	X	-	I, T	I, T	I, T	I, T			Thorny, thicket forming, requires consistent runoff, poisonous seeds, pink flowers in Spring
<i>Salix gooddingii</i>	Goodding's willow	25' x 25'				X	-	I	-	-	-			Riparian only, high water needs
<i>Sapindus saponaria</i> var. <i>drummondii</i>	Western soapberry	30' x 30'	X			X	-	I, T	I	I, T	I, T			Slow grower, white flowers in summer followed by inedible fruits
<i>Styphnolobium japonicum</i>	Japanese pagoda tree	35' x 25'	X			X	I, T	I, T	I, T	I, T	I, T			White flowers in summer
<i>Ulmus parvifolia</i> (and hybrids)	Lacebark elm	40' x 30'	X			X	-	I, T	I	I, T	I, T			Non-invasive, elm beetle resistant
<i>Vitex agnus castus</i>	Chaste tree	20' x 20'	X			X	I, T	I, T	I, T	-	-			
<i>Ziziphus jujuba</i> *	Jujube	25' x 25'	X	X	X	X	I, T	I, T	I, T	I, T	I, T			Thicket-forming barrier plant

Notes: More testing is needed on *Gymnocladus dioica* (questionable drought tolerance) and *Ulmus propinqua* (potentially invasive). Several additional trees were considered for this list and were not included due to concerns with heat and-or drought tolerance, including *Celtis occidentalis*, *Gleditsia triacanthos*, *Juglans major* and *nigra*, *Juniperus scopulorum*, *Prunus cistena*, and *Quercus buckleyi*. In general, trees provide important habitat for birds and pollinators. Conifers (pines and junipers on this list) do not provide the same benefit to pollinators as most deciduous trees.

\* Indicates tree is not recommended as street trees because of growth habit, thorns, fruit production, and/or root development.

Shrubs

Botanical Name	Common Name	Mature Size (Height x Spread)	Biome					Elevation Zone and Infiltration Zone (I = inundation, T = transition, H= high ground)					Wildlife Value		Evergreen / Semi-	Notes	
			Urban Ephemeral Riparian	Urban Grassland/ Shrubland	Shrub Desert	Riparian	West Mesa	Valley	East Mesa	Foothills	E. Mtn.	Pollinator	Bird				
<b>SHRUBS</b>																	
<i>Amorpha canescens</i>	Leadplant	3' x 3'	X	X	X	X	I	I	I	I	LT	X					
<i>Amorpha fruticosa</i>	False indigo	10' x 10'	X			X	-	I	-	-	LT	X					Phytoremediator for lead and perchlorate
<i>Anisacanthus wrightii</i>	Desert honeysuckle	5' x 4'	X	X	X	X	LT	LT	LT	LT	-	X	X				Bright red-orange flowers in early summer and when well watered
<i>Arctostaphylos x coloradoensis</i>	Chieftan or Panchito manzanita	2' x 4'	X	X	X		T,H	T,H	T,H	T,H	T,H	X	X	E			Requires good drainage
<i>Artemisia filifolia</i>	Sand sage	4' x 4'	X	X	X		T,H	T,H	T,H	T,H	T,H		X	E			Requires good drainage, only give one year establishment irrigation
<i>Artemisia tridentata</i>	Big sage	4' x 4'	X	X	X		LT,H	-	LT,H	LT,H	LT,H	X	X	E			
<i>Atriplex canescens</i>	Four-winged saltbush	5' x 7'	X	X	X	X	T,H	T,H	T,H	T,H	T,H		X	E			Allergen-producing, use sparingly, will reseed, salt tolerant
<i>Atriplex lentiformis</i>	Quail bush	8' x 8'	X	X	X	X	T	T	T	T	-		X	E			Good for large spaces
<i>Baccharis salicifolia</i>	Mulefat	8' x 6'	X			X	LT	LT	LT	-	-	X		SE			Sticky foliage
<i>Baccharis salicina</i>	Seep willow	6' x 6'	X			X	-	LT	-	-	-	X	X	SE			Locally native
<i>Baccharis sarothroides</i>	Desert broom	10' x 10'	X	X		X	LT,H	T,H	LT,H	-	-	X	X	SE			
<i>Baccharis 'Starn Thompson'</i>	Starn Thompson broom	4' x 5'	X	X	X	X	-	LT	-	LT	-			E			Sterile cultivar
<i>Buddleia marrubifolia</i>	Wooly butterfly bush	4' x 4'	X	X	X	X	T,H	T,H	T,H	-	-	X	X	SE			
<i>Caesalpinia gilestii</i>	Yellow brd of paradise	5' x 5'	X	X	X	X	T,H	T,H	T,H	T,H	-	X	X				
<i>Caryopteris x clandonensis</i>	Blue mist spirea	4' x 4'	X	X		X	I	I	I	LT	LT	X					
<i>Cercocarpus breviflorus</i>	Hairy mountain mahogany	10' x 8'	X	X		X	-	-	T	T,H	T,H	X	X	SE			Slow growing
<i>Cercocarpus ledifolius</i>	Curleaf mountain mahogany	10' x 12'	X	X		X	-	-	T	T,H	T,H	X	X	E			Slow growing
<i>Cercocarpus montanus</i>	Mountain mahogany	8' x 10'	X	X		X	-	-	T	T,H	T,H	X	X	SE			Slow growing
<i>Chamaebatiaria millefolium</i>	Fernbush	6' x 8'	X	X	X	X	LT	LT	LT	LT	LT,H	X	X				
<i>Dalea capitata</i>	Sierra gold dalea	1' x 3'	X	X	X	X	T	T	T	-	-		X	SE			Very heat tolerant
<i>Ephedra nevadensis</i>	Nevada jointfir	4' x 4'	X	X	X		T,H	-	T,H	T,H	-	X	X	E			
<i>Ephedra viridis</i>	Green ephedra	2' x 4'	X	X	X		T,H	-	T,H	T,H	-	X	X	E			
<i>Eriocameria laricina</i>	Turpentine bush	3' x 4'	X	X	X		LT,H	LT,H	LT,H	LT,H	LT,H	X		E			Fall-blooming, important late-season nectar source for bees
<i>Eriocameria nauseosa</i>	Chamisa- Rabbitbrush	5' x 8'	X	X	X		LT,H	LT,H	LT,H	LT,H	LT,H	X	X	E			Flowers have foul odor
<i>Eriogonum fasciculatum</i>	Flat-top buckwheat	1' x 2'	X	X	X		T,H	-	T,H	T,H	-	X	X				
<i>Eriogonum wrightii</i>	Wright's buckwheat	1' x 2'	X	X	X		T,H	-	T,H	T,H	-	X	X				
<i>Fallugia paradoxa</i>	Apache plume	6' x 7'	X	X	X	X	LT,H	LT,H	LT,H	LT,H	LT,H	X	X	SE			
<i>Forestiera neomexicana</i>	New Mexico olive	12' x 12'	X	X		X	-	LT	LT	LT,H	LT,H	X	X				
<i>Garrya wrightii</i>	Wright's silktassel	6' x 6'	X	X		X	T,H	T,H	T,H	T,H	T,H			E			
<i>Hesperaloe parviflora</i>	Red yucca	3' x 3'	X	X	X		T,H	T,H	T,H	T,H	T,H	X	X	E			
<i>Krascheninnikovia lanata</i>	Winterfat	3' x 3'		X	X		LT,H	LT,H	LT,H	LT,H	LT,H		X	SE			
<i>Larrea tridentata</i>	Creosote bush	6' x 6'	X	X	X		T,H	-	T,H	-	-	X	X	E			Yellow flowers in spring and winter
<i>Leucophyllum spp</i>	Texas ranger	3-6' x 3-6'	X	X	X	X	T,H	T,H	T,H	-	-	X		SE			Best species: <i>L. langmaniae</i> 'Lynn's Legacy' and 'Rio Bravo', <i>L. frutescens</i> 'Compacta' and 'Green Cloud', <i>L. revolutum</i> 'Houdini'
<i>Lycium andersonii</i>	Anderson wolfberry	6' x 6'	X	X	X	X	LT,H	LT,H	LT,H	LT,H	-	X	X	E			Salt tolerant
<i>Mahonia haematocarpa</i>	Red mahonia- barberry	6' x 5'	X	X	X	X	LT,H	LT,H	LT,H	LT,H	LT,H	X	X	E			Yellow flowers in spring followed by red berries
<i>Mahonia triflora</i>	Algerita	6' x 8'	X	X	X	X	LT,H	LT,H	LT,H	LT,H	LT,H	X	X	E			Yellow flowers in spring followed by red berries
<i>Nolina microcarpa</i>	Beargrass	5' x 7'		X	X		T,H	T,H	T,H	T,H	-	X	X	E			
<i>Nolina nelsonii</i>	Blue nolina	8' x 4'		X	X		T,H	T,H	T,H	-	-	X		E			
<i>Nolina texana</i>	Beargrass	3' x 3'		X	X		T,H	T,H	T,H	T,H	T,H	X	X	E			Locally native
<i>Prunus americana</i>	Wild plum	10' x 10'	X			X	I	I	I	LT	LT	X	X				
<i>Prunus besseyi</i>	Western sand cherry	5' x 5'	X	X	X	X	T,H	T,H	T,H	T,H	T,H	X	X				
<i>Prunus besseyi 'Pawnee Buttes'</i>	Pawnee Buttes sand cherry	2' x 6'	X	X	X	X	T,H	T,H	T,H	T,H	T,H	X	X				Groundcover variety of Western sand cherry
<i>Prunus virginiana var melanocarpa</i>	Western choke cherry	10' x 10'	X	X		X	-	LT	I	LT	LT	X	X				Select from local provenance
<i>Purshia mexicana</i>	Cliff Rose	8' x 8'	X	X	X		T,H	-	T,H	T,H	T,H	X	X	E			Fragrant
<i>Purshia tridentata</i>	Antelope bitterbrush	5' x 5'	X	X	X		T,H	-	T,H	T,H	T,H	X	X	SE			
<i>Rhus glabra 'Cismontana'</i>	Compact smooth sumac	5' x 7'	X	X		X	-	LT	LT	LT,H	LT,H	X	X				Thicket-forming
<i>Rhus microphylla</i>	Littleleaf sumac	8' x 9'	X	X	X	X	LT	LT	LT	LT,H	LT,H	X	X				
<i>Rhus trilobata</i>	Three leaf sumac	6' x 6'	X	X	X	X	LT,H	LT,H	LT,H	LT,H	LT,H		X				Locally native
<i>Rhus trilobata 'Autumn Amber'</i>	Prostrate three-leaf sumac	2' x 6'	X	X	X	X	LT,H	LT,H	LT,H	LT,H	LT,H	X					Groundcover variety of Three leaf sumac (locally native)
<i>Salix exigua</i>	Coyote willow	5' x 3'				X	-	I	I	I	I	X	X				Root sprouts, bank stabilizer
<i>Salvia chamaedryoides</i>	Mexican blue sage	1' x 2'	X	X			-	T	T	T	-	X		SE			Does well in clay
<i>Salvia greggii</i>	Autumn or Cherry sage	2' x 3'	X	X	X	X	LT	LT	LT	LT	LT	X	X	SE			Brittle, blooms from spring to fall
<i>Salvia officinalis</i>	Culinary sage	2' x 3'	X	X	X	X	LT	LT	LT	LT	LT	X		SE			Can be used for cooking
<i>Salvia pachyphylla</i>	Mojave sage	2' x 3'		X	X		-	T	T	T,H	T,H	X		SE			
<i>Salvia rosmarinus</i>	Rosemary	3' x 3'	X			X	T	T	T	-	-	X		E			
<i>Santolina chamaecyparissus</i>	Grey santolina	2' x 3'	X	X			T	T	T	T	T			E			
<i>Santolina virens</i>	Green santolina	2' x 3'	X	X			T	T	T	T	T			E			
<i>Teucrium arsanium</i>	Gray creeping germander	4' x 2'	X	X		X	T	T	T	T	T	X		E			
<i>Teucrium chamaedrys</i>	Wall germander	2' x 2'	X	X		X	LT	LT	LT	LT	LT	X		E			
<i>Vauquelinia californica ssp</i>	Arizona rosewood	12' x 10'	X	X			T,H	T,H	T,H	T,H	-	X	X	E			Does well with high winds

Notes: Several additional shrubs were considered for this list and were not included due to concerns with heat and/or drought tolerance, including *Rhus aromatica* 'Gro-Low', *Buddleia davidii*, and *Lavandula* spp.

### Perennials

Botanical Name	Common Name	Mature Size (Height x Spread)	Biome				Elevation Zone and Infiltration Zone (I = inundation, T = transition, H = high ground)					Wildlife Value		Notes
			Urban Ephemeral Riparian	Urban Grassland/ Shrubland	Shrub Desert Grassland	Riparian	West Mesa	Valley	East Mesa	Foothills	E. Mntn	Pollinator	Bird	
<b>HERBACEOUS PERENNIALS AND ANNUAL WILDFLOWERS</b>														
<i>Achillea millefolium</i>	Common yarrow	1' x 1'	X	X	X	X	-	I,T	I,T	I,T	I,T	X		
<i>Artemisia frigida</i>	Fringed sage	1' x 1'	X	X	X		I,T,H	I,T,H	I,T,H	I,T,H	I,T,H	X	X	
<i>Artemisia ludoviciana</i>	Prairie sage	2' x 3'	X	X	X	X	-	I,T,H	I,T,H	I,T,H	I,T,H	X		Spreads by rhizomes
<i>Asclepias speciosa</i>	Showy milkweed	3' x 1'	X			X	I	I,T	I,T	I,T	I,T	X	X	
<i>Asclepias subverticillata</i>	Horsetail milkweed	2' x 2'	X	X	X	X	I	I	I	I	I,T	X		
<i>Baileya radiata</i>	Desert marigold	1' x 1'	X	X	X		T,H	T,H	T,H	T,H	T,H	X	X	Biennial, prolific reseeder
<i>Berlandiera lyrata</i>	Chocolate flower	1' x 2'	X	X	X	X	T,H	-	T,H	T,H	T,H	X	X	Will reseed
<i>Calylophus hartwegii</i>	Sundrops	1' x 2'	X	X	X		T	-	T	T,H	T,H	X		
<i>Centranthus ruber</i>	Red Valerian	2' x 2'	X	X	X	X	I,T	I,T	I,T	I,T	I,T,H	X		Tolerant of a variety of conditions, will reseed
<i>Cirsium neomexicanum</i>	New Mexico thistle	6' x 2'	X	X	X		I,T,H	I,T,H	I,T,H	I,T,H	I,T,H	X	X	Locally native, non-invasive
<i>Cleome serrulata</i>	Rocky Mountain beeplant	3' x 3'	X	X	X	X	I,T	I,T	I,T	I,T	I,T,H	X	X	Annual, available as seed
<i>Datura wrightii</i>	Sacred datura	2' x 6'	X	X	X	X	I,T,H	I,T,H	I,T,H	I,T,H	I,T,H	X	X	All parts of plant are toxic, only plant in inaccessible basins.
<i>Epilobium canum</i>	Hummingbird trumpet	1' x 3'	X			X	-	I,T	-	I,T	I,T	X	X	
<i>Euphorbia rigida</i>	Gopher spurge	2' x 3'	X	X	X		T	T	T	T	-	X		Handle with caution- sap can burn skin. Will reseed
<i>Gaillardia aristata</i>	Blanketflower	1' x 1'	X	X	X		T,H	T,H	T,H	T,H	T,H	X		Reseeds readily
<i>Glandularia gooddingii</i>	Goodding's verbena	1' x 1'	X			X	T	T	T	T	T	X		Requires water to bloom
<i>Glandularia rigida</i>	Sandpaper verbena	2' x 4'	X	X	X	X	T	T	T	-	-	X		
<i>Helianthus annuus</i>	Common sunflower	4-6' tall	X	X	X	X	-	I,T,H	-	-	I,T,H	X	X	Annual, great for birds, bees, and butterflies (available as seed), phytoremidator of hydrocarbons and metals
<i>Helianthus petiolaris</i>	Prairie sunflower	4' x 4'	X	X		X	I,T,H	I,T,H	I,T,H	I,T,H	I,T,H	X	X	Annual, great for birds, bees, and butterflies (available as seed)
<i>Hymenoxys acaulis</i>	Angelita daisy	1' x 1'	X	X	X		T,H	T,H	T,H	T,H	T,H	X		Reblooms throughout spring and summer
<i>Linum lewisii</i>	Blue flax	2' x 2'	X	X		X	I,T,H	I,T,H	I,T,H	I,T,H	I,T,H	X		
<i>Melampodium leucanthum</i>	Blackfoot daisy	1' x 2'		X	X		T,H	-	T,H	T,H	T,H	X	X	Long-lived, will reseed
<i>Mirabilis multiflora</i>	Desert four o'clock	2' x 3'	X	X	X	X	T,H	-	T,H	T,H	T,H	X		Will reseed
<i>Monarda fistulosa</i>	Wild beebalm	2' x 2'	X	X	X	X	-	-	-	I,T,H	I,T,H	X		
<i>Nepeta racemosa</i>	Catmint	2' x 2'	X	X		X	T	T	T	T	T	X		Blooms spring to fall
<i>Oenothera caespitosa</i>	White tufted evening primrose	1' x 2'	X	X	X	X	T,H	T,H	T,H	T,H	T,H	X		Short-lived, but reseeds readily
<i>Oenothera speciosa</i>	Mexican evening primrose	1' x 2'	X	X	X	X	I,T	I,T	I,T	I,T	I,T	X	X	Needs some water and sunlight to bloom
<i>Oenothera lindheimeri</i>	Gaura	3' x 3'	X			X	I,T	I,T	I,T	I,T	I,T	X		
<i>Penstemon ambiguus</i>	Sand penstemon	2' x 2'	X	X			I,T,H	I,T,H	I,T,H	I,T,H	I,T,H	X	X	Usually available as seed
<i>Penstemon thurberi</i>	Thurber's penstemon	2' x 2'	X	X	X		I,T,H	I,T,H	I,T,H	I,T,H	-	X	X	
<i>Psilotrophe tagetina</i>	Wooly paperflower	1' x 2'		X	X		T,H	T,H	T,H	T,H	T,H	X		
<i>Ratibida columnifera</i>	Mexican hat	1' x 1'	X	X	X	X	I,T,H	I,T,H	I,T,H	I,T,H	I,T,H	X	X	
<i>Salvia darcyi</i>	Vermillion Bluffs sage	3' x 3'	X	X		X	-	T	T	T	T	X	X	Great for hummingbirds
<i>Sphaeralcea spp</i>	Globemallow	2' x 2'	X	X	X	X	I,T,H	I,T,H	I,T,H	I,T,H	I,T,H	X	X	Short-lived, reseeds
<i>Symphotrichum ericoides</i>	White heath aster	2' x 2'	X	X	X	X	-	I,T,H	-	I,T,H	I,T,H	X		Bosque native
<i>Zinnia acerosa</i>	Desert zinnia	1' x 1'	X	X	X		T,H	-	T,H	T,H	-	X	X	
<i>Zinnia grandiflora</i>	Prairie zinnia	0.5' x 1'	X	X	X		T,H	-	T,H	T,H	T,H	X	X	

Notes: Penstemons require well-drained soils and do not tolerate inundation. The Penstemons listed above (ambiguus and thurberi) are the exceptions that have been observed to tolerate some inundation. However, many Penstemons (including eatonii, parryi, pinifolius, pseudospectabilis, strictus, and superbus) may do well in areas around GSI features. If conditions are favorable, they will reseed themselves into wetter soil.

### Grasses

Botanical Name	Common Name	Mature Size (Height x Spread)	Biome				Elevation Zone and Infiltration Zone (I = inundation, T = transition, H= high ground)					Wildlife Value		Notes
			Urban Ephemeral Riparian	Urban Grassland/ Shrubland	Shrub Desert Grassland		West Mesa	Valley	East Mesa	Foothills	E. Mntn	Pollinator	Bird	
<b>GRASSES</b>														
<i>Andropogon gerardii</i>	Big bluestem	4' x 2'				X	-	I,T	-	I,T	I,T	X	X	Salt tolerant , phytoremediation of hydrocarbons, some heavy metals, and PCBs (through accumulation)
<i>Aristida purpurea</i>	Purple three-awn	1' x 1'		X	X		T,H	T,H	T,H	T,H	T,H	X	X	Available as seed, good for erosion control and reclamation
<i>Bouteloua curtipendula</i>	Sideoats grama	2' x 2'	X	X	X		T,H	T,H	T,H	T,H	T,H	X	X	
<i>Bouteloua gracilis</i>	Blue grama	2' x 2'	X	X	X		T,H	T,H	T,H	T,H	T,H	X	X	Helps to break down hydrocarbons
<i>Distichlis spicata</i>	Desert saltgrass	2' tall, spreading				X	I	I	I	I	I	X	X	Available as seed, high salt tolerance, higher water needs, mat forming
<i>Elymus elymoides</i>	Squirreltail	1' x 1'	X	X	X		T,H	T,H	T,H	T,H	T,H			Seed heads can be dangerous for pets, good for reclamation
<i>Elymus lanceoalotus ssp psammophilus</i>	Streambank wheat	1' x 2'	X	X	X	X	-	I,T	-	I,T	I,T			Sod-forming
<i>Eragrostis trichodes</i>	Sand lovegrass	3' x 3'	X	X	X		T,H	T,H	T,H	T,H	T,H	X		
<i>Festuca glauca</i>	Blue fescue	1' x 1'					-	-	-	-	T			
<i>Muhlenbergia asperifolia</i>	Alkali muhly/Scratchgrass	2' x 2'	X	X	X	X	-	I,T	-	-	-			Salt tolerant
<i>Muhlenbergia capillaris</i>	Regal mist	3' x 3'	X			X	I,T	-	I,T	I,T	I,T		X	High salt tolerance
<i>Muhlenbergia emersleyi</i>	Bull grass	3' x 3'	X			X	I,T	I,T	I,T	I,T	-	X	X	
<i>Muhlenbergia lindheimerii</i>	Autumn glow muhly	5' x 5'	X			X	I,T	I,T	I,T	I,T	-		X	
<i>Muhlenbergia porteri</i>	Bush muhly	1' x 3'	X	X	X		T,H	T,H	T,H	T,H	T,H		X	Usually available as seed
<i>Muhlenbergia rigens</i>	Deer grass	4' x 4'	X	X	X	X	I,T	I,T	I,T	I,T	I,T	X	X	
<i>Muhlenbergia rigida</i>	Nashville muhly	2' x 3'	X	X	X	X	I,T	I,T	I,T	I,T	I,T	X		
<i>Nassella tenuissima</i>	Mexican feather grass	2' x 2'	X	X	X	X	I,T,H	I,T,H	I,T,H	I,T,H	I,T,H			Will reseed. Only plant where spreading is desired.
<i>Panicum obtusum</i>	Vine mesquite	2', spreading	X	X	X	X	I,T	I,T	I,T	I,T	I,T	X		Available as seed, mat forming
<i>Panicum virgatum</i>	Switchgrass	3' x 2'	X			X	-	I	-	-	I,T	X	X	
<i>Pascopyrum'-Agropyron smithii</i>	Western wheat grass	2' x 2'	X			X	-	I,T	-	I,T	I,T,H		X	Helps to break down hydrocarbons, can crowd out wildflowers, tolerates poor drainage
<i>Pleuraphis jamesii</i>	Galleta grass	1' x 1'	X	X	X		T,H	T,H	T,H	T,H	T,H	X	X	
<i>Schizachyrium scoparium</i>	Little bluestem	2' x 2'	X	X	X	X	I,T,H	T,H	I,T,H	I,T,H	T,H	X	X	Helps to break down hydrocarbons
<i>Sorghastrum nutans</i>	Indiangrass	4' x 2'	X			X	I,T	I,T	I,T	I,T	I,T	X	X	Helps to break down hydrocarbons, tolerates poor drainage
<i>Sporobolus airoides</i>	Alkali sacaton	2' x 2'	X	X	X	X	I,T,H	I,T,H	I,T,H	I,T,H	I,T,H	X	X	Tolerates salinity and inundation
<i>Sporobolus cryptandrus</i>	Sand dropseed	2' x 2'		X	X		T,H	T,H	T,H	T,H	T,H	X	X	
<i>Sporobolus wrightii</i>	Giant sacaton	5' x 5'	X			X	I,T	I,T	I,T	I,T	I,T	X	X	Tolerates salinity and inundation





**BERN**  
**CO** | Bernalillo  
County